



PARTS CATALOGUE

YW100 (5XB4) C SOUTH AMERICA

YW100 (5XR3) MEXICO



1F5XB-200S1



YW100
PARTS CATALOGUE
©2006 by Yamaha Motor Co., Ltd.
1st edition, September 2006
All rights reserved.
Any reprinting or unauthorized use
without the written permission of
Yamaha Motor Co., Ltd.
is expressly prohibited.

YW100
CATALOGO DE REPUESTOS
©2006 por Yamaha Motor Co., Ltd.
1ª edición, septiembre 2006
Todos los derechos reservados.
Toda reproducción o uso no autorizado
sin el consentimiento escrito de
Yamaha Motor Co., Ltd.
quedan expresamente prohibidos

FOREWORD

This Parts Catalogue is related to the parts for the model(s) on the cover page. When you are ordering replacement parts, please refer to this Parts Catalogue and quote both part numbers and part names correctly.

1. Modifications or additions which have been made after the issue of the Parts Catalogue will be announced in the Parts News.

It is advisable that you make the necessary corrections to the Parts Catalogue according to the Parts News.

2. Abbreviations

The following abbreviations are used in this Parts Catalogue.

“UR” Use specified parts number.

“UN” Use as many as needed.

“AP” Alternate Parts

“LM” Locally Made (Parts need to be ordered locally)

“F#” Frame No. (Applicable machine No.)

“O/S” Over Size

3. The number of components for assembly

- Parts, which are to be supplied in an assembly, are listed with a dot (.) in front of the part name as shown below.
- The numeral appearing to the right of each component part indicates the quantity of parts for each assembly unit.

PART NO.	DESCRIPTION	Q'TY	REMARKS
2F5-83310-60	FRONT FLASHER LIGHT ASSY	2	
115-83311-60	.BULB (6V-18W)	1	

4. Applicable colours of graphics are represented in the “REMARKS” as shown below.

PART NO.	DESCRIPTION	Q'TY	REMARKS
2N4-24110-00-X5	FUEL TANK COMP.	2	MXR
3J1-24240-10	.GRAPHIC, FUEL TANK	1	FOR MXR

5. Note that the illustrations for reference in finding parts numbers are not to be used for assembling. When assembling, please use the applicable service manual.

6. The asterisk (*) before a reference number indicates modified items after the first edition.

PROLOGO

Este catálogo de repuestos corresponde a las piezas para el o los modelos que figuran en la página de portada. Al formular el pedido de repuestos, se ruega citar este catálogo y especificar correctamente el número y el nombre de las piezas.

1. Las modificaciones y agregados que se hayan realizado después de la edición de este Catálogo de Repuestos, serán anunciados en las Informaciones de Recambios. Es recomendable que se hagan las correcciones necesarias en el Catálogo de Repuestos de acuerdo con las Informaciones de Recambios.

2. Abreviaciones

En este. Catálogo de Repuestos se emplean las siguientes abreviaciones.

“UR” Usar el número de partes especificado

“UN” Usar la cantidad necesaria

“AP” Piezas sustitutivas

“LM” Fabricación local (Hay que pedir los repuestos en las cercanías)

“F#” N° de bastidor (N° aplicable a la máquina)

“O/S” Sobredimensionado

3. La cantidad de componentes para el montaje

- Los componentes, suministrados como conjunto, se describen con un punto (.) que precede al nombre del parte como se indica a continuación.
- La numeración que aparece a la derecha de cada descripción indica la cantidad de partes por cada unidad de conjunto.

CODIGO N°	DESCRIPCION	CANT.	OBSERVACIONES
2F5-83310-60	ENSAMBLAJE DE LA LUZ	2	
115-83311-60	.BOMBILLA (6V-18W)	1	

4. Los colores de los componentes se indican como sigue en la columna de “OBSERVACIONES”.

CODIGO N°	DESCRIPCION	CANT.	OBSERVACIONES
2N4-24110-00-X5	COMP. DEL TANQUE	2	MXR
3J1-24240-10	.GRAFICO, DEL TANQUE	1	PARA MXR

5. Debe tenerse en cuenta que las ilustraciones sirven como guía para la búsqueda de los números de partes y no deben usarse para el montaje. Durante el montaje, se recomienda usar el manual de taller correspondiente.

6. EL asterisco (*) antes del número de referencia indica los elementos modificados después de la primera edición.

FOREWORD

7. Applicable Serial No.

Engine Serial No.

Frame Serial No.

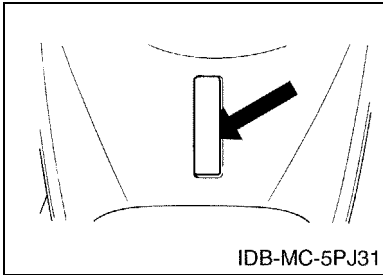
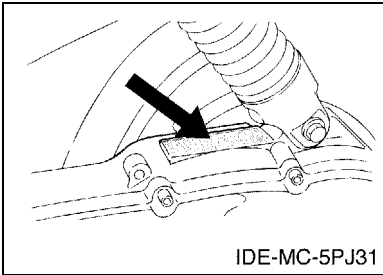

8. Applicable Colour Code (The (*) mark shows Model colour.)

Abbreviation	Colour Name	Colour Code
DPBMC(*)	DEEP PURPLISH BLUE METALLIC C	0564
FS	FAIRY SILVER	001V
LGB	LOW GLOSS BLACK	0098
SMX(*)	BLACK METALLIC X	0903
VRS5(*)	VIVID RED SOLID 5	0268
VYS2(*)	VIVID YELLOW SOLID 2	0657
YB	YAMAHA BLACK	0033

PROLOGO

7. Números de serie

Nº de Serie del motor

Nº de Serie del bastidor

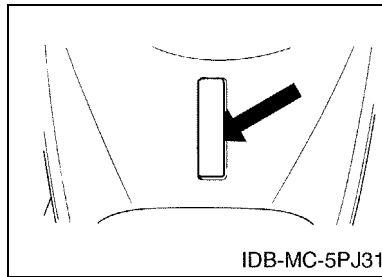
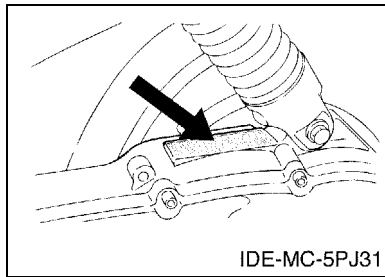

8. Códigos de color aplicables (El símbolo (*) muestra el color de modelo.)

Abreviatura	Nombre de color	Código de color
DPBMC(*)	DEEP PURPLISH BLUE METALLIC C	0564
FS	FAIRY SILVER	001V
LGB	LOW GLOSS BLACK	0098
SMX(*)	BLACK METALLIC X	0903
VRS5(*)	VIVID RED SOLID 5	0268
VYS2(*)	VIVID YELLOW SOLID 2	0657
YB	YAMAHA BLACK	0033

ROTULO DE MODELO

(1) El rótulo llamada "Rótulo de Modelo" está en la ubicación indicada abajo en el (3). Cuando se utilice este catálogo de repuestos, se ruega cotejar entre el "código de modelo-número de código de producción" del catálogo y el "código de modelo-número de código de producción" indicado en el Rótulo de Modelo fijado en el producto correspondiente.

(2) Indicación del "Rótulo de Modelo"

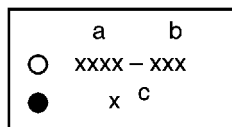

a: Código de tipo de Modelo

b: Número de código de Producción

c: Tipo de color

(3) Ubicación de fijación del Rótulo de Modelo

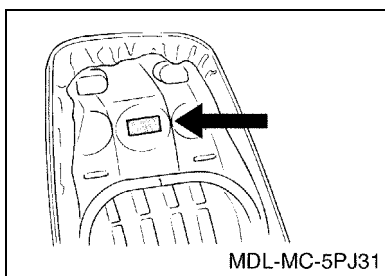

(4) Información de Color

Código de Modelo	Código de tipo de color	Código de color	Nombre de color	Abreviatura
5XB4	A	0564	DEEP PURPLISH BLUE METALLIC C	DPBMC
	B	0903	BLACK METALLIC X	SMX
	C	0657	VIVID YELLOW SOLID 2	VYS2
	D	0268	VIVID RED SOLID 5	VRS5
5XR3	A	0564	DEEP PURPLISH BLUE METALLIC C	DPBMC
	B	0903	BLACK METALLIC X	SMX
	C	0657	VIVID YELLOW SOLID 2	VYS2
	D	0268	VIVID RED SOLID 5	VRS5

(5) Código de Modelo-Número de código de Producción del Modelo Listado en este Catálogo de Repuestos

Código de Modelo	Número de Código de Producción	País (destino)	Código de Modelo	Número de Código de Producción	País (destino)
5XB4	010	C SOUTH AMERICA			
5XR3	010	MEXICO			

CONTENTS

ENGINE

CYLINDER	1
CRANKSHAFT & PISTON	2
AIR SHROUD & FAN	3
OIL PUMP	4
INTAKE	5
CARBURETOR	6
EXHAUST	7
CRANKCASE	8
STARTER	10
CLUTCH	11
TRANSMISSION	13

CHASSIS

FRAME	14
FENDER	15
SIDE COVER	16
OIL TANK	18
REAR SUSPENSION	19
FRONT FORK	20
FUEL TANK	22
SEAT	23
FRONT WHEEL	24
FRONT BRAKE CALIPER	25
REAR WHEEL	26
STEERING HANDLE & CABLE	27
FRONT MASTER CYLINDER	28
STAND	29
LEG SHIELD	30
COWLING 1	32
GENERATOR	33
STARTING MOTOR	34
FLASHER LIGHT	35
METER	36
HEADLIGHT	37
TAILLIGHT	38
HANDLE SWITCH & LEVER	39
ELECTRICAL 1	40
ELECTRICAL 2	41

INDEX

NUMERICAL INDEX	42
-----------------------	----

CONTENIDO

MOTOR

CILINDRO	1
CIGUENAL & PISTON	2
CUBIERTA DE AIRE & VENTILADOR	3
BOMBA DE ACEITE	4
ADMISION	5
CARBURADOR	6
DESCARGA	7
CARTER	8
ARRANQUE	10
EMBRAGUE	11
TRANSMISION	13

SHASIS

CUADRO	14
GUARDABARRO	15
CUBIERTA LATERAL	16
DEPOSITO DE ACEITE	18
SUSPENSION TRASERO	19
HORQUILLA DELANTERA	20
DEPOSITO DE COMBUSTIBLE	22
ASIENTO	23
RUEDA DELANTERA	24
CALIBRE FRENO DELANTERA	25
RUEDA TRASERA	26
MANILLAR & CABLE	27
CILINDRO MAESTRO DELANTERO	28
SOPORTE	29
PATA PROTEGIDA	30
BOVEDA 1	32
GENERADOR	33
MOTOR DE ARRANQUE	34
LUZ DE DESTELLADOR	35
MEDIDOR	36
FARO DELANTERO	37
LUZ DE COLA	38
INTERRUPTOR DE MANILLAR&PALANC	39
EQUIPO ELECTRICO 1	40
EQUIPO ELECTRICO 2	41

INDICE

INDICE NUMERICO	42
-----------------------	----

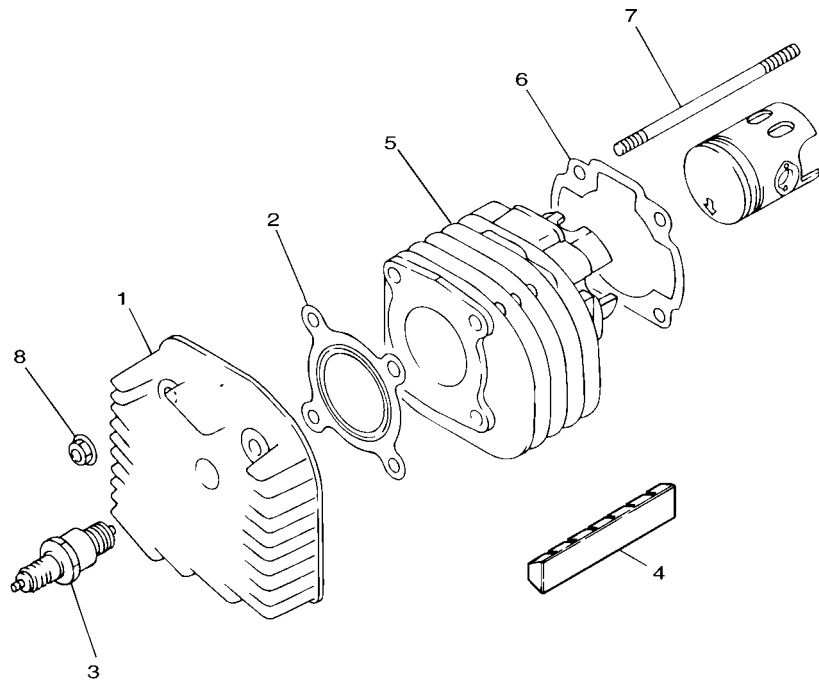



4VP5200-7010

FIG. 1 CYLINDER

CILINDRO

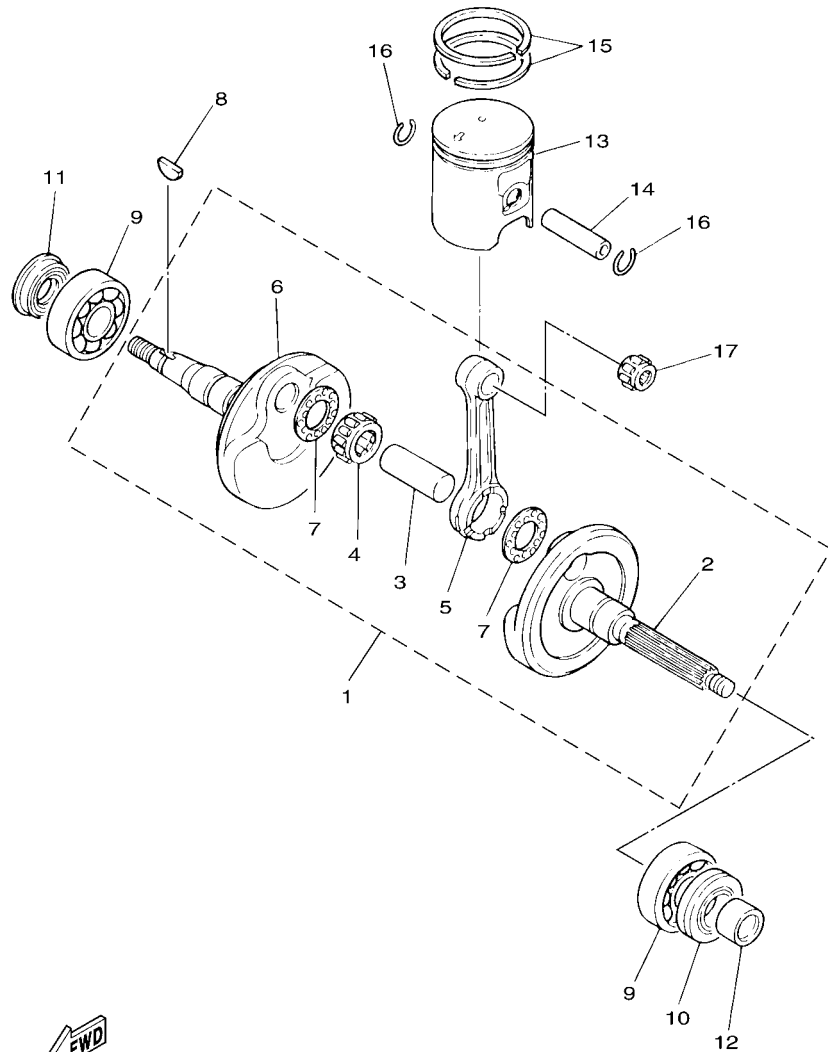
REF. NO.	PART NO. CODIGO Nº	DESCRIPTION DESCRIPCION	5XB4	5XR3	REMARKS OBSERVACIONES
1	4VP-E1111-00	HEAD, CYLINDER 1 CULATA CILINDRO 1	1	1	
2	4VP-E1181-00	GASKET, CYLINDER HEAD 1 JUNTA, DE CULATA 1	1	1	
3	94700-00825	PLUG, SPARK BUJIA	1	1	
4	4VP-E1162-00	ABSORBER 2 AMORTIGUADOR 2	1	1	
5	4VP-E1311-10-A0	CYLINDER 1 CILINDRO 1	1	1	
6	5FA-E1351-00	GASKET, CYLINDER JUNTA, DE CILINDRO	1	1	
7	90116-07834	BOLT, STUD ESPARRAGO	4	4	
8	90179-07381	NUT TUERCA	4	4	



 3NW1414-9020

FIG. 2 CRANKSHAFT & PISTON

CIGUENAL & PISTON

REF. NO.	PART NO. CODIGO Nº	DESCRIPTION DESCRIPCION	5XB4	5XR3	REMARKS OBSERVACIONES
1	4VP-E1400-00	CRANKSHAFT ASSY CIGUENAL COMPLETO	1	1	
2	4VP-E1412-00	.CRANK 1 .MANIVELA 1	1	1	
3	4DM-E1681-00	.PIN, CRANK 1 .PASADOR MANIVELA 1	1	1	
4	93310-41810	.BEARING .COJINETE DE RODILLOS	1	1	
5	4VP-E1651-00	.ROD, CONNECTING .BIELA	1	1	
6	4VP-E1422-00	.CRANK 2 .MANIVELA 2	1	1	
7	90209-18112	.WASHER .ARANDELA DE SEPARACION	1	1	
8	90280-03017	KEY, WOODRUFF CUNA WOODRUFF	1	1	
9	93306-205Y6	BEARING COJINETE	2	2	
10	93102-22464	OIL SEAL SELLO ACEITE	1	1	
11	93101-20169	OIL SEAL SELLO ACEITE	1	1	
12	90387-178N6	COLLAR ESPACIADOR	1	1	
13	4VP-E1631-10-A0	PISTON (STD) PISTON (NORMA)	1	1	
14	4VP-E1633-00	PIN, PISTON PASADOR, PISTON	1	1	
15	4VP-E1603-00	PISTON RING SET (STD) JUEGO DE ANILLOS (NORMA)	1	1	
16	93450-16115	CIRCLIP SEGURO	2	2	
17	93310-21403	BEARING COJINETE DE RODILLOS	1	1	

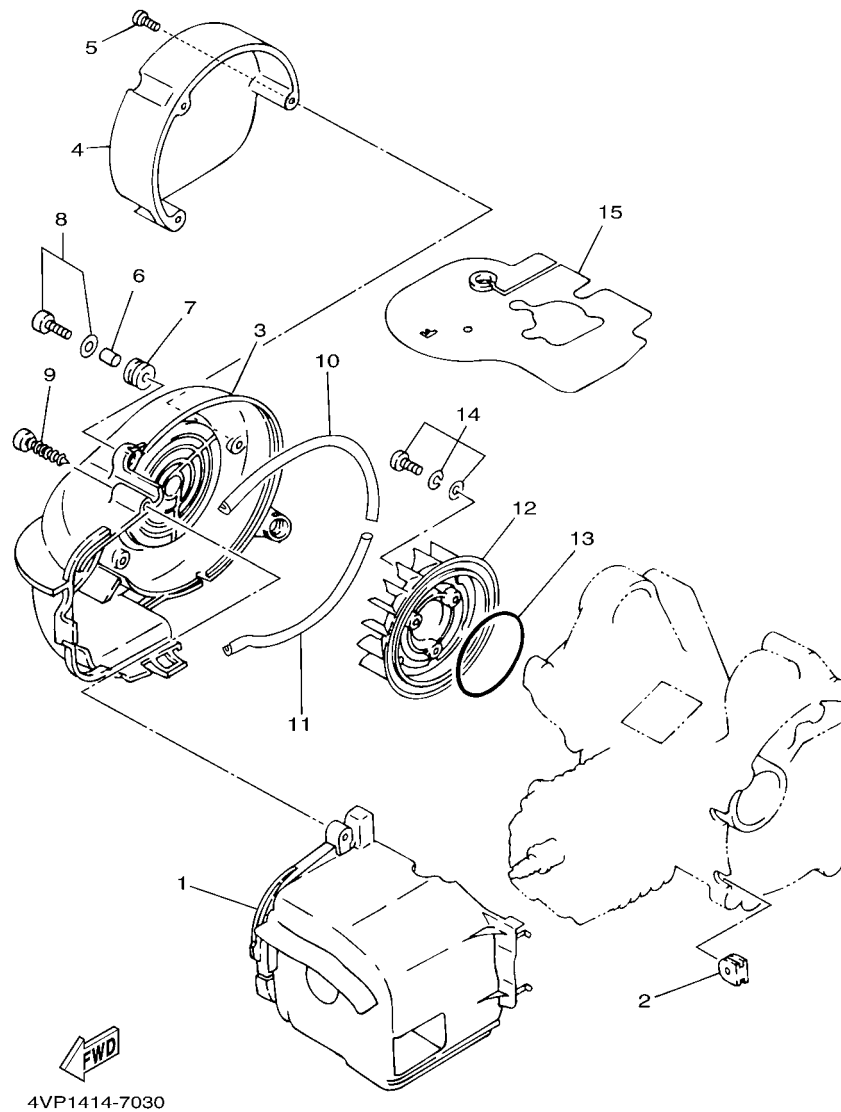

FIG. 3 AIR SHROUD & FAN

CUBIERTA DE AIRE & VENTILADOR

REF. NO.	PART NO. CODIGO N°	DESCRIPTION DESCRIPCION	5XB4	5XR3	REMARKS OBSERVACIONES
1	5FA-E2651-10	AIR SHROUD, CYLINDER 1 CUBIERTA DE PASO DE AIRE 1	1	1	
2	90480-11866	GROMMET TAPON	1	1	
3	5FA-E2653-02	AIR SHROUD, CYLINDER 3 CUBIERTA DE PASO DE AIRE 3	1	1	
4	4DY-E262H-00	GUIDE 1 GUIA 1	1	1	
5	97707-40514	SCREW, TAPPING TORNILLO ROSCA HEMBRA	3	3	
6	90387-068J5	COLLAR ESPACIADOR	3	3	
7	90480-12497	GROMMET TAPON	3	3	
8	97607-06220	SCREW, WITH WASHER TORNILLO CAB CON PLANA C/ARAN	3	3	
9	97707-60540	SCREW, TAPPING TORNILLO ROSCA HEMBRA	1	1	
10	4VP-E2658-00	DAMPER, AIR SHROUD 1 AMORTIGUADOR DE CUBIERTA 1	1	1	
11	4VP-E2659-00	DAMPER, AIR SHROUD 2 AMORTIGUADOR DE CUBIERTA 2	1	1	
12	4VP-E2611-00	FAN VENTILADOR	1	1	
13	93210-64893	O-RING ANILLO O	1	1	
14	90119-06857	BOLT, WITH WASHER TORNILLO CON ARANDELA	3	3	
15	3XG-E2631-00	DEFLECTOR 1 DEFLECTOR 1	1	1	

FIG. 4 OIL PUMP

BOMBA DE ACEITE

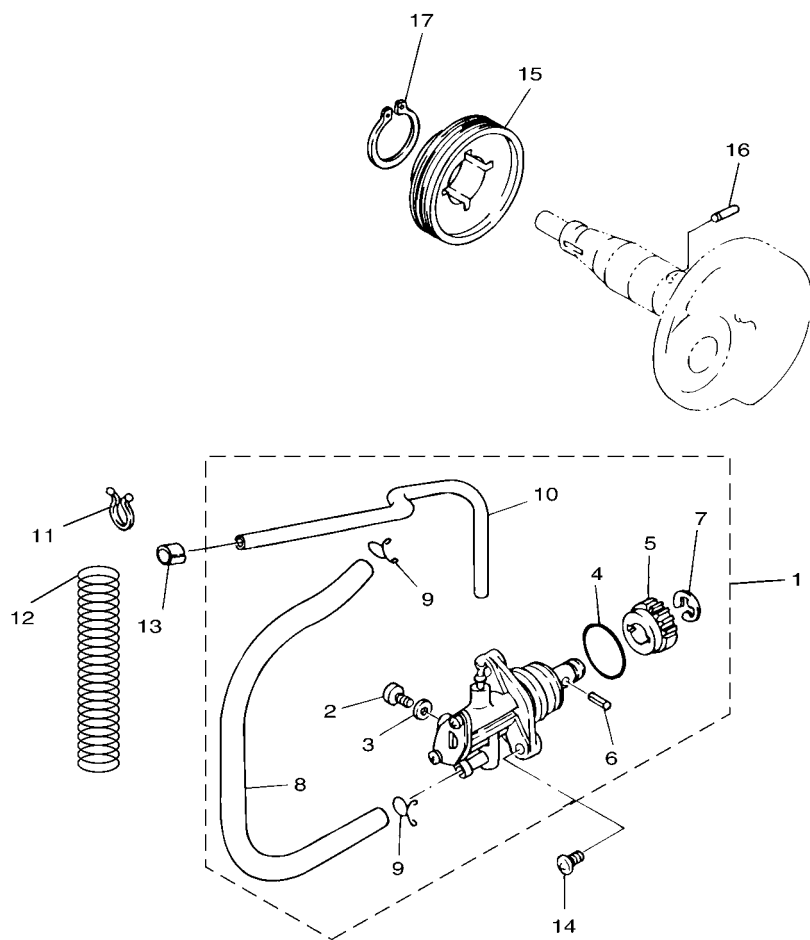

4VP1414-7042

REF. NO.	PART NO. CODIGO Nº	DESCRIPTION DESCRIPCION	5XB4	5XR3	REMARKS OBSERVACIONES
1	5FA-E3100-11	OIL PUMP ASSY BOMBA DE ACEITE COMPLETA	1	1	
2	3WF-13185-00	.BOLT, BREATHER .PERNO DE RESPIRADERO	1	1	
3	1YU-13187-00	.GASKET, BREATHER BOLT .EMPAQUE TORNILLO P/RESPIRADER	1	1	
4	1YU-13473-00	.O-RING .ANILLO O	1	1	
5	3AA-13124-00	.GEAR WORM WHEEL (40T) .ENGREJE ROSCA SINFIN (40T)	1	1	
6	1YU-13516-00	.PIN, DOWEL .PASADOR, DE ESPIGA	1	1	
7	1YU-13577-00	.CLIP .PRESILLA	1	1	
8	4VP-E316F-00	.HOSE, OIL 1 .MANGUERA, DE ACEITE 1	1	1	
9	90467-08003	.CLIP .PRESILLA	2	2	
10	90445-05431	.HOSE (L240) .TUBO (L240)	1	1	
11	90464-16801	CLAMP BRIDA	1	1	
12	90501-08845	SPRING, COMPRESSION RESORTE DE COMPRESION	1	1	
13	90468-02033	CLIP PRESILLA	1	1	
14	98507-05014	SCREW, PAN HEAD TORNILLO DE CABEZA PLANA	2	2	
15	4VP-13178-00	GEAR, PUMP DRIVE ENGRANAJE TRACC.DE BOMBA	1	1	
16	93603-12827	PIN, DOWEL PASADOR DE CLAVIJA	1	1	
17	99009-19400	CIRCLIP PRESILLA REDONDA	1	1	

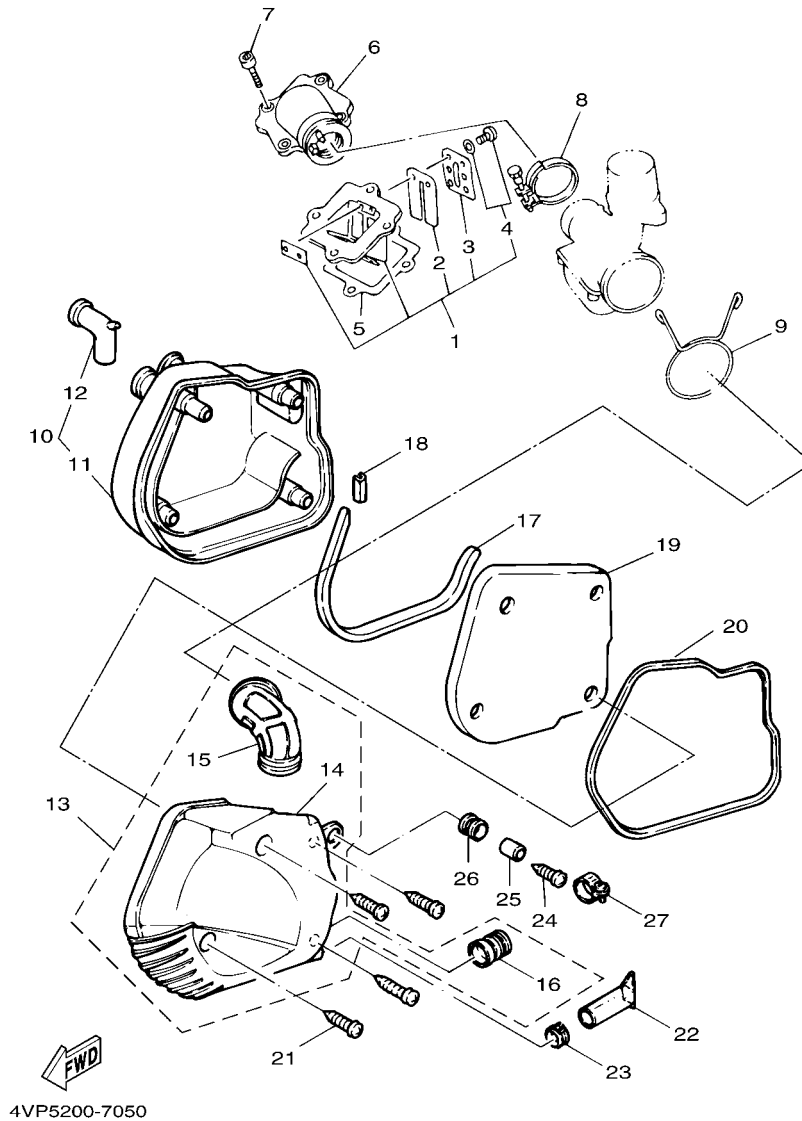

FIG. 5 INTAKE

ADMISION

REF. NO.	PART NO. CODIGO Nº	DESCRIPTION DESCRIPCION	5XB4	5XR3	REMARKS OBSERVACIONES
1	4VP-E3610-00	REED VALVE ASSY VALVULA DE LAMINAS COMPLETA	1	1	
2	3XG-E3613-00	.REED, VALVE .VALVULA DE LAMINAS	2	2	
3	3XG-E3616-00	.STOPPER, REED VALVE .TOPE DE VALVULA DE LAMINAS	2	2	
4	97607-03206	.SCREW,WITH WASHER .TORNILLO CAB CON PLANA C/ARAN	4	4	
5	4SC-E3621-00	GASKET, VALVE SEAT JUNTA, DE VALV,DE EMPAQUE	1	1	
6	4WX-E3555-10	MANIFOLD, INTAKE CONECTOR	1	1	
7	91318-06020	BOLT TORNILLO	4	4	
8	3XG-E3575-01	BAND BANDA	1	1	
9	90467-01800	CLIP PRESILLA	1	1	
10	4VP-W1441-00	AIR CLEANER CASE COMP. CAJA COMPLETO FILTRO DE AIRE	1	1	
11	4VP-E4411-00	.CASE, AIR CLEANER 1 .CAJA FILTRO DEL AIRE 1	1	1	
12	4VP-E4437-00	.DUCT .CONDUCTO	1	1	
13	4VP-W1442-00	AIR CLEANER CASE COMP. ELEMENTO DE FILTRO DE AIRE	1	1	
14	4VP-E4412-00	.CAP, CLEANER CASE 1 .TAPA CAJA DEL FILTRO 1	1	1	
15	4VP-E4453-00	.JOINT, AIR CLEANER 1 .UNION DEL FILTRO DEL AIRE 1	1	1	
16	4VP-E4463-00	.JOINT, AIR CLEANER 2 .UNION DE FILTRO DE AIRE 2	1	1	
17	4VP-E4462-00	SEAL SELLO	1	1	
18	4VP-E4467-00	SEAL SELLO	1	1	
19	4VP-E4451-00	ELEMENT, AIR CLEANER ELEMENTO DEL FILTRO DEL AIRE	1	1	
20	4VP-E4452-00	SEAL SELLO	1	1	
21	97707-50125	SCREW, TAPPING TORNILLO ROSCA HEMBRA	4	4	
22	4VP-E443E-00	PIPE, DRAIN TUBO, DRENAJE	1	1	
23	90467-11823	CLIP PRESILLA	1	1	
24	97607-06220	SCREW,WITH WASHER TORNILLO CAB CON PLANA C/ARAN	1	1	
25	90387-068J5	COLLAR ESPACIADOR	1	1	
26	90480-12497	GROMMÉT TAPON	1	1	
27	90460-41191	CLAMP, HOSE BRIDA, DE UNION	1	1	

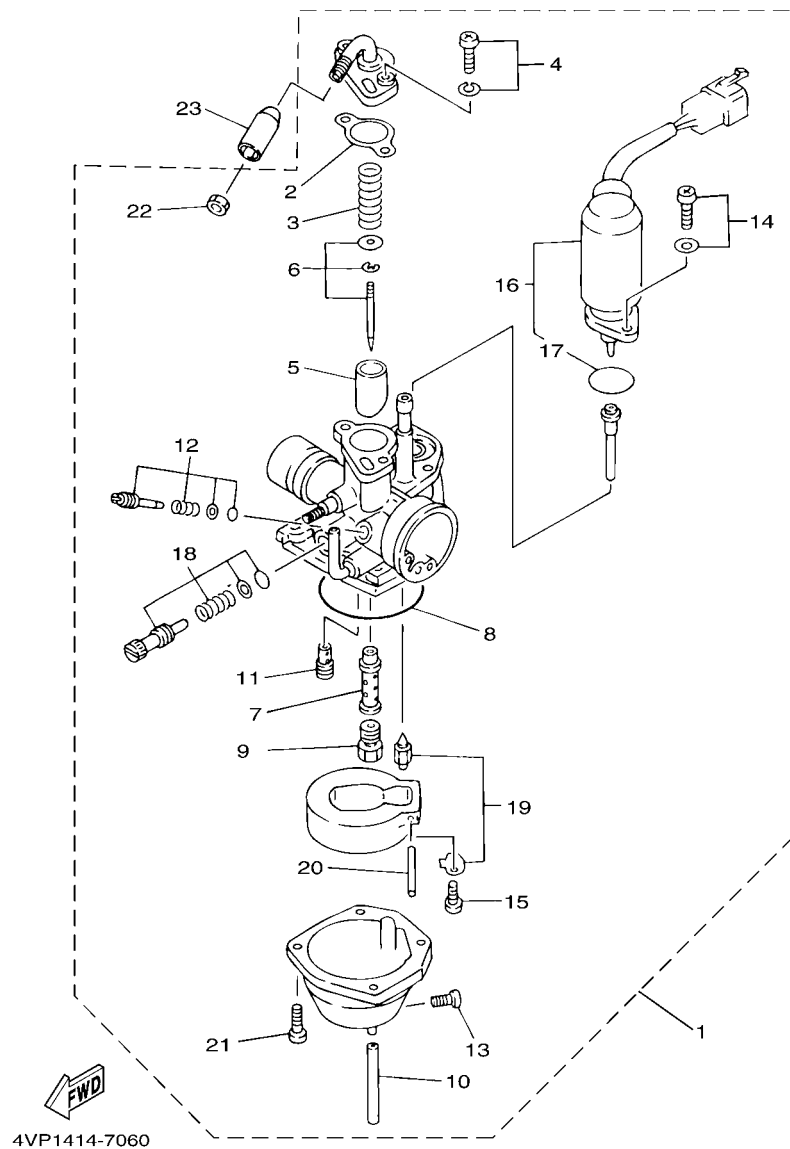

FIG. 6 CARBURETOR

CARBURADOR

REF. NO.	PART NO. CODIGO N°	DESCRIPTION DESCRIPCION	5XB4	5XR3	REMARKS OBSERVACIONES
1	5JU-E4101-00	CARBURETOR ASSY 1 CARBURADOR COMPLETO 1	1	1	
2	3XG-14198-00	.GASKET .EMPAQUE	1	1	
3	52W-14131-00	.SPRING, THROTTLE VALVE .RESORTE VALVULA DE ACELERACION	1	1	
4	97607-04112	.SCREW, WITH WASHER .TORNILLO CAB CON PLANA C/ARAN	2	2	
5	4VP-14112-35	.VALVE, THROTTLE 1 .VALVULA DE ACELERACION 1	1	1	
6	4VP-1490J-00	.NEEDLE SET .CJTO. AGUJA	1	1	
7	4VP-14141-11	.NOZZLE, MAIN .BOQUILLA PRINCIPAL	1	1	
8	3XG-14997-00	.SEAL .SELLO	1	1	
9	18A-1414A-65	.JET, MAIN (# 72.5) .INYECTOR, PRINCIPAL (# 72.5)	1	1	
10	3XG-14196-00	.PIPE .TUBO DE DRENASE	1	1	
11	193-14142-35	.JET, PILOT (#35) .SURTIADOR DE RALENTI (# 35)	1	1	
12	3MB-14104-00	.AIR SCREW SET .CJTO. TORNILLO DE AIRE	1	1	
13	4KP-14191-00	.PLUG, DRAIN .TORNILLO, DE DRENAJE	1	1	
14	97607-04108	.SCREW, WITH WASHER .TORNILLO CAB CON PLANA C/ARAN	2	2	
15	98507-03006	.SCREW, PAN HEAD .TORNILLO DE CABEZA PLANA	1	1	
16	4VP-14171-00	.PLUNGER, STARTER .EMBOLO DE ARRANQUE	1	1	
17	52W-14147-00	.O-RING .ANILLO O	1	1	
18	4UF-14103-00	.THROTTLE SCREW SET .CJTO. TORNILLO DEL RALENTI	1	1	
19	3XG-14107-00	.NEEDLE VALVE SET .VALVULA DE AGUJA	1	1	
20	53L-14186-00	.PIN, FLOAT .PASADOR DE LA BOYA	1	1	
21	98507-04012	.SCREW, PAN HEAD .TORNILLO DE CABEZA PLANA	4	4	
22	522-14161-00	.NUT, CABLE ADJUSTING .TUERCA AJUSTADOR DE CABLE	1	1	
23	1MH-F6329-00	CAP, RUBBER TAPA DE ANILLO PROTECTOR	1	1	

FIG. 7 EXHAUST

DESCARGA

REF. NO.	PART NO. CODIGO Nº	DESCRIPTION DESCRIPCION	5XB4	5XR3	REMARKS OBSERVACIONES
1	5JU-E4610-00-98	EXHAUST PIPE ASSY 1 TUBO DE ESCAPE COMPLETO 1	1	1	LGB FOR DPBMC,... LGB FOR DPBMC,...
2	4VP-E4445-00	GROMMET TAPON PROTECTOR	1	1	
3	4VP-E4779-00	COLLAR COLLAR	1	1	
4	3NT-E4613-01	GASKET, EXHAUST PIPE JUNTA, TUBO DE ESCAPE	1	1	
5	90153-06800	SCREW, HEXAGON TORNILLO HEXAGONAL	2	2	
6	95817-08020	BOLT, FLANGE TORNILLO	1	1	
7	95817-08030	BOLT, FLANGE TORNILLO	1	1	
8	4VP-E4718-00	PROTECTOR, MUFFLER 1 PROTECTOR DE SILENCIADOR 1	1	1	
9	4VP-E4627-10	EXT.COVER ASSY PROTECTOR DE SILENCIADO	1	1	
10	97017-06010	BOLT PERNO	2	2	
11	4CW-E4766-00	WASHER, PROTECTOR ARANDELA DE PROTECTOR	4	4	
12	97517-06510	BOLT, WITH WASHER PERNO CON ARANDELA	3	3	
13	4VP-E4799-20	CAP TAPA	1	1	
14	4VP-E475M-00	PIPE TUBO	1	1	
15	92907-06200	WASHER ARANDELA	3	3	
16	90176-06065	NUT, CROWN TUERCA CORONA	3	3	
17	4CW-E4766-00	WASHER, PROTECTOR ARANDELA DE PROTECTOR	3	3	
18	98980-06010	SCREW, BIND TORNILLO DE LIGAR	3	3	
19	3XY-E4766-00	WASHER, PROTECTOR ARANDELA DE PROTECTOR	3	3	

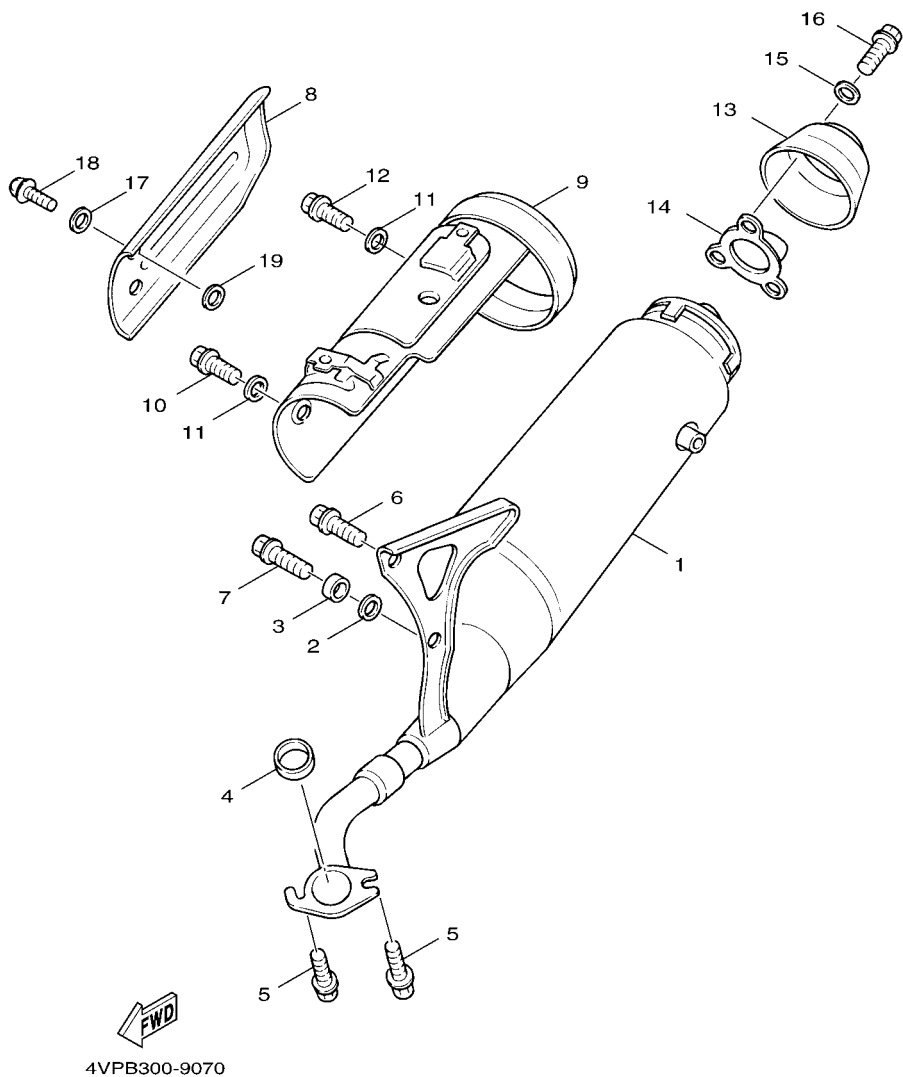

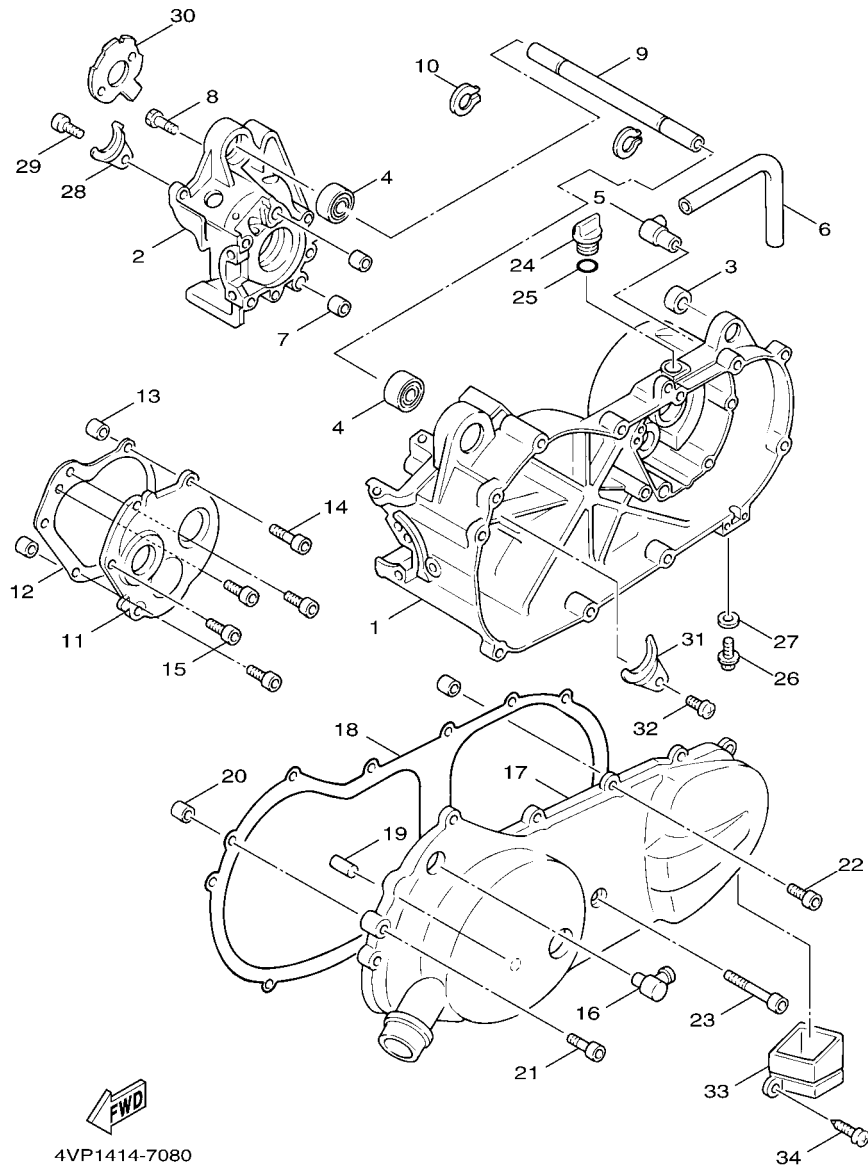

4VP1414-7080

FIG. 8 CRANKCASE

CARTER

REF. NO.	PART NO. CODIGO Nº	DESCRIPTION DESCRIPCION	5XB4	5XR3	REMARKS OBSERVACIONES
1	5FA-E5111-12	CRANKCASE 1 CARTER MANIVELA 1	1	1	
2	4VP-E5121-00	CRANKCASE 2 CARTER MANIVELA 2	1	1	
3	4X6-F2216-00	BUSH, REAR SHOCK ABSORBER BUJE DEL AMORTIGUADOR TRASERO	1	1	
4	93306-003Y4	BEARING COJINETE	2	2	
5	3XG-E5371-00	BREATHER RESPIRADERO	1	1	
6	4VP-E5373-00	PIPE, BREATHER MANGUELA DE RESPIRADERO	1	1	
7	91812-16805	PIN, DOWEL PASADOR DE CLAVIJA	2	2	
8	91318-06035	BOLT TORNILLO	6	6	
9	3XG-E5317-00	SPACER, ENGINE MOUNT SEPARADPR, MONTANTE DE MOTOR	1	1	
10	99009-17400	CIRCLIP PRESILLA REDONDA	2	2	
11	4VP-E5421-01	COVER, CRANKCASE 2 TAPA DE CARTER DERECHA	1	1	
12	5DA-E5461-00	GASKET, CRANKCASE COVER 2 JUNTA TAPA CARTER DERECHO 2	1	1	
13	91810-14807	PIN, DOWEL PASADOR DE CLAVIJA	2	2	
14	91318-06035	BOLT TORNILLO	2	2	
15	91318-06020	BOLT TORNILLO	4	4	
16	4VP-E5439-00	PLUG, BLIND TAPON CIEGO	1	1	
17	4VP-E5411-00-33	COVER, CRANKCASE 1 CUBIERTA DE CARTER 1	1	1	YB FOR DPBMC,S...
18	5DA-E5451-00	GASKET, CRANKCASE COVER 1 EMPAQ DE CUBIERTA DE CARTER	1	1	YB FOR DPBMC,S...
19	4VP-E5659-00	SHAFT EJE	1	1	
20	91810-14807	PIN, DOWEL PASADOR DE CLAVIJA	2	2	
21	91317-06025	BOLT PERNO	9	9	
22	91317-06035	BOLT PERNO	2	2	
23	91317-06045	BOLT PERNO	1	1	
24	4Y4-E5363-00	PLUG, OIL TAPON DE ACEITE	1	1	
25	93210-14805	O-RING ANILLO O	1	1	
26	95807-08016	BOLT, FLANGE TORNILLO	1	1	
27	90430-08119	GASKET JUNTA	1	1	

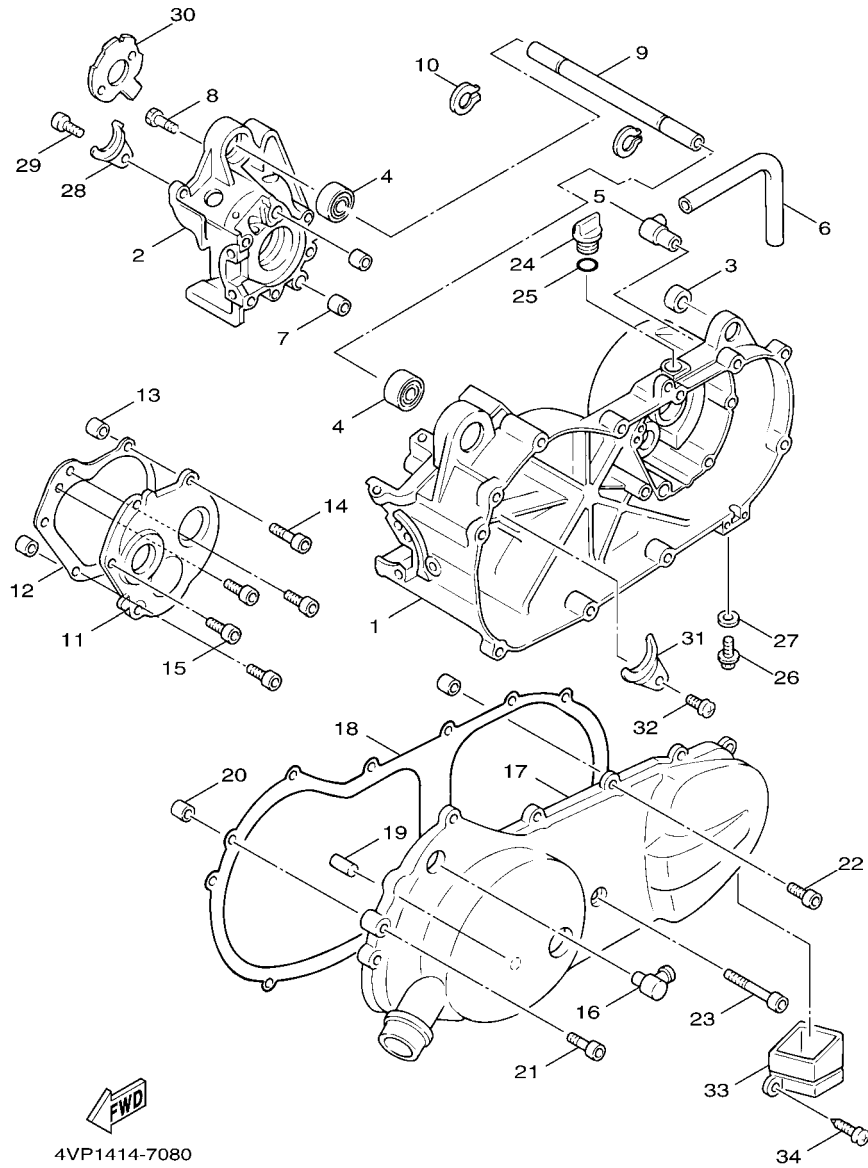

4VP1414-7080

FIG. 8 CRANKCASE

CARTER

REF. NO.	PART NO. CODIGO Nº	DESCRIPTION DESCRIPCION	5XB4	5XR3	REMARKS OBSERVACIONES
28	4VP-E5128-00	HOLDER SOPORTE	1	1	
29	98507-06012	SCREW, PAN HEAD TORNILLO DE CABEZA PLANA	1	1	
30	4SC-E5462-00	GASKET, CRANKCASE COVER 3 EMPAQ CUBIERTA DE CARTER 3	1	1	
31	4VP-E5118-00	HOLDER SOPORTE	1	1	
32	98507-06012	SCREW, PAN HEAD TORNILLO DE CABEZA PLANA	1	1	
33	4VP-E5477-00	DUCT, AIR CONDCTO DE AIRE	1	1	
34	97607-06220	SCREW, WITH WASHER TORNILLO CAB CON PLANA C/ARAN	2	2	

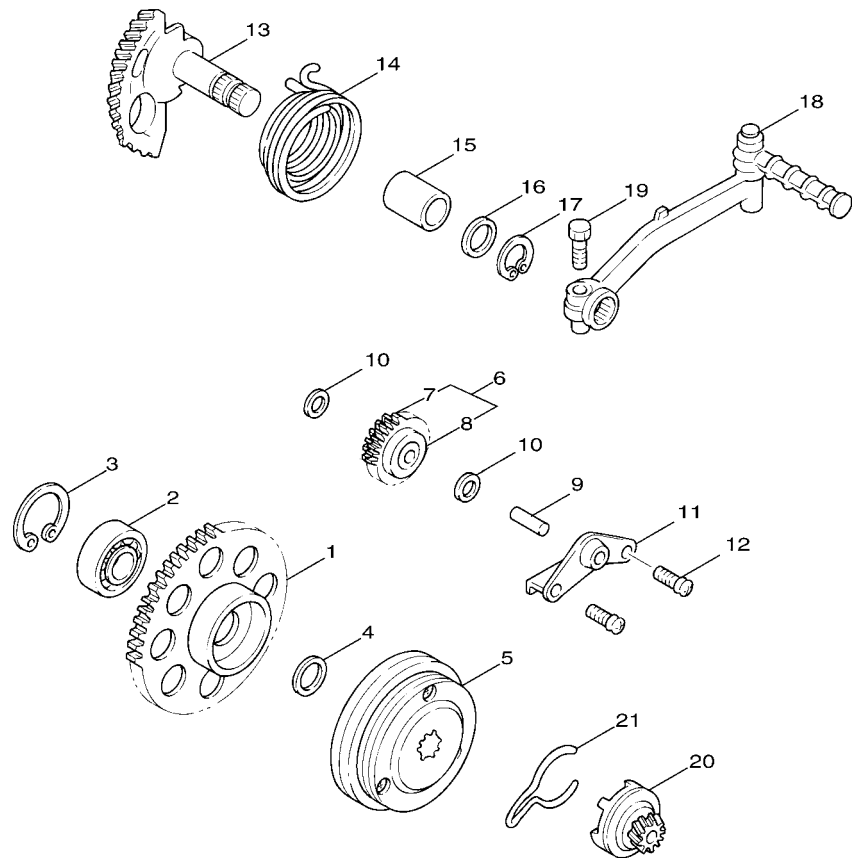

4VP1414-7090

FIG. 9 STARTER

ARRANQUE

REF. NO.	PART NO. CODIGO Nº	DESCRIPTION DESCRIPCION	5XB4	5XR3	REMARKS OBSERVACIONES
1	4VP-E5524-00	WHEEL, STARTER RUEDA DE ARRANQUE	1	1	
2	93306-003Y4	BEARING COJINETE	1	1	
3	93450-35015	CIRCLIP SEGURO	1	1	
4	90201-163G6	WASHER, PLATE ARANDELA PLANA	1	1	
5	4CW-E5570-00	STARTER CLUTCH ASSY EMBRAGUE DEL ARRANQUE COMPLETA	1	1	
6	4VP-E5650-00	IDLE GEAR ASSY ENGRENAJE NEUTRO COMPLETO	1	1	
7	4VP-E5512-00	.GEAR, IDLER 1 .ENGRENAJE NEUTRO	1	1	
8	93315-108Y4	.BEARING .COJINETE DE RODILLOS	1	1	
9	3XG-E3342-00	SHAFT, IDLE GEAR EJE DE ENGRENAGE NEUTRO	1	1	
10	90201-08088	WASHER, PLATE ARANDELA PLANA	2	2	
11	3XG-E5532-00	PLATE, IDLE GEAR PLACA DE ENGRENAGE NEUTRO	1	1	
12	98507-06012	SCREW, PAN HEAD TORNILLO DE CABEZA PLANA	2	2	
13	4VP-E5601-00	KICK SHAFT ASSY EJE DE ARR. DE PIE COMPL	1	1	
14	90508-32768	SPRING, TORSION RESORTE DE TORSION	1	1	
15	90380-15817	BUSH, SOLID CASQUILLO SOLIDO	1	1	
16	90201-155G5	WASHER, PLATE ARANDELA PLANA	1	1	
17	99009-15400	CIRCLIP PRESILLA REDONDA	1	1	
18	5FA-E5620-00	KICK CRANK ASSY PEDAL DE ARRANQUE COMPLETO	1	1	
19	97017-06025	BOLT PERNO	1	1	
20	4VP-E5630-00	KICK PINION ASSY PINON DE PEDAL COMPLETA	1	1	
21	4VP-E5673-00	CLIP PRESILLA	1	1	

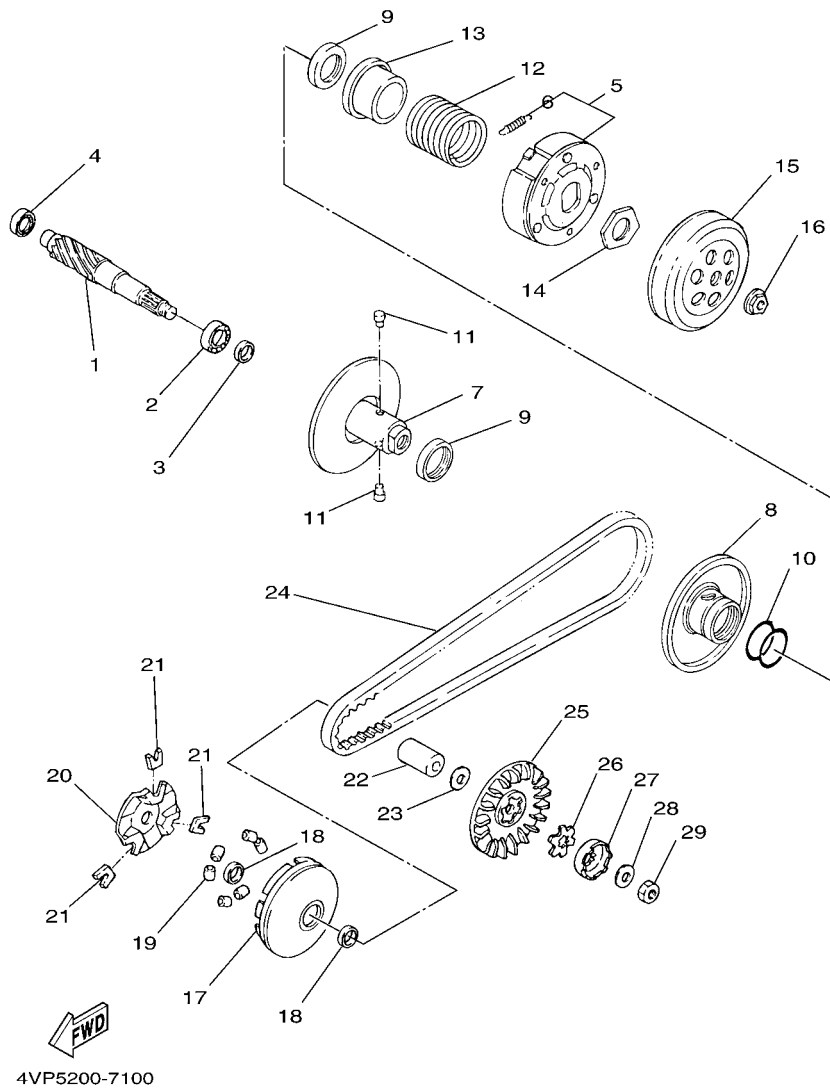
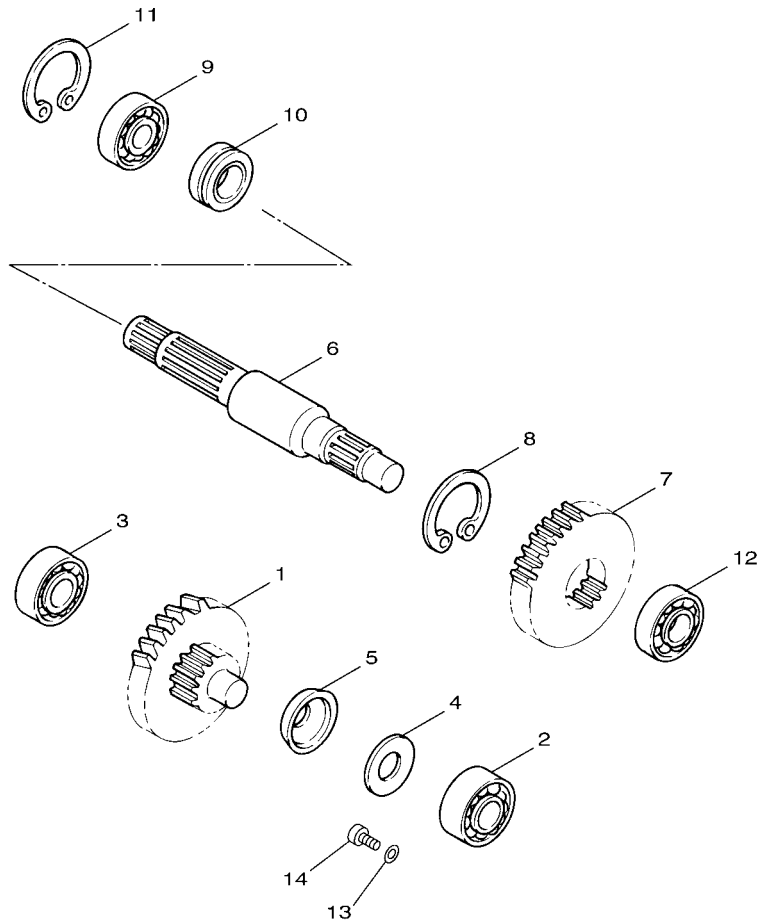

FIG. 10 CLUTCH

EMBRAGUE

REF. NO.	PART NO. CODIGO Nº	DESCRIPTION DESCRIPCION	5XB4	5XR3	REMARKS OBSERVACIONES
1	4VP-E6111-01	GEAR, PRIMARY DRIVE ENGRANAJE TRACC.PRIMARIA	1	1	
2	93306-203YE	BEARING COJINETE	1	1	
3	93102-17467	OIL SEAL SELLO ACEITE	1	1	
4	93306-200Y1	BEARING COJINETE	1	1	
5	3XY-E6620-01	CLUTCH CARRIER ASSY PORTADOR DE EMBRAGUE COMPLETO	1	1	
6	3UH-E6626-00	.SPRING, CLUTCH WEIGHT 1 .RESORTE CONTRAPESO EMBRAGUE	3	3	
7	4VP-E7660-01	SECONDARY FIXED SHEAVE COMP. ROLDANA SECUNDARIA FIJA COMPL.	1	1	
8	4VP-E7670-01	SECONDARY SLIDING SHEAVE ROLDANA SECUNDARIA CORREDIZA	1	1	
9	93104-33800	OIL SEAL SELLO ACEITE	2	2	
10	93210-368G9	O-RING ANILLO O	2	2	
11	4DM-E7664-00	PIN, GUIDE PASADOR DE GUIA	2	2	
12	90501-430K3	SPRING, COMPRESSION RESORTE DE COMPRESION	1	1	
13	4DM-E7684-00	SEAT, SECONDARY SPRING ASIENTO DE RESORTE SECUNDARIO	1	1	
14	90179-28415	NUT TUERCA	1	1	
15	4VP-E6611-00	CLUTCH HOUSING COMP. CAJA DE EMBRAGUE COMPLETO	1	1	
16	90179-10609	NUT TUERCA	1	1	
17	4VP-E7620-00	PRIMARY SLIDING SHEAVE COMP. ROLDANA PRIMARIA MOVIL	1	1	
18	93101-21801	OIL SEAL SELLO ACEITE	2	2	
19	4KX-17632-00	WEIGHT CONTRAPESO	6	6	
20	4VP-E7623-00	CAM LEVA	1	1	
21	4CW-E7653-00	SLIDER CORREDERA	3	3	
22	90387-168N7	COLLAR ESPACIADOR	1	1	
23	90201-16800	WASHER, PLATE ARANDELA PLANA	1	1	
24	4VP-17641-00	V-BELT CORREA EN V	1	1	
25	4VP-E7611-00	SHEAVE, PRIMARY FIXED PISCO FIXADOR DE POREA	1	1	
26	90209-14800	WASHER ARANDELA DE SEPARACION	1	1	
27	14T-15657-00	CLUTCH, ONEWAY EMBRAQUE SIN RETORNO	1	1	



5XB3200-E110

FIG. 11 TRANSMISSION

TRANSMISION

REF. NO.	PART NO. CODIGO N°	DESCRIPTION DESCRIPCION	5XB4	5XR3	REMARKS OBSERVACIONES
1	4VP-E7410-01	MAIN AXLE COMP. EJE PRINCIPAL COMPLETO	1	1	
2	93311-315Y2	BEARING COJINETE DE RODILLOS	1	1	
3	93306-200Y1	BEARING COJINETE	1	1	
4	90201-15819	WASHER, PLATE ARANDELA PLANA	1	1	
5	90208-21801	WASHER, CONICAL SPRING ARANDELA DE RESORTE CONICO	1	1	
6	4VP-E7421-01	AXLE, DRIVE EJE SECUNDARIO	1	1	
7	4VP-E7211-01	GEAR, 1ST WHEEL ENGRANAJE RUEDA DE 1 RA	1	1	
8	93410-20823	CIRCLIP SEGURO	1	1	
9	93306-004X7	BEARING COJINETE	1	1	
10	93102-25270	OIL SEAL SELLO ACEITE	1	1	
11	99009-42500	CIRCLIP PRESILLA REDONDA	1	1	
12	93306-203YE	BEARING COJINETE	1	1	
13	90201-06847	WASHER, PLATE ARANDELA PLANA	1	1	
14	95027-06010	BOLT, FLANGE PERNO, DE BRIDA	1	1	

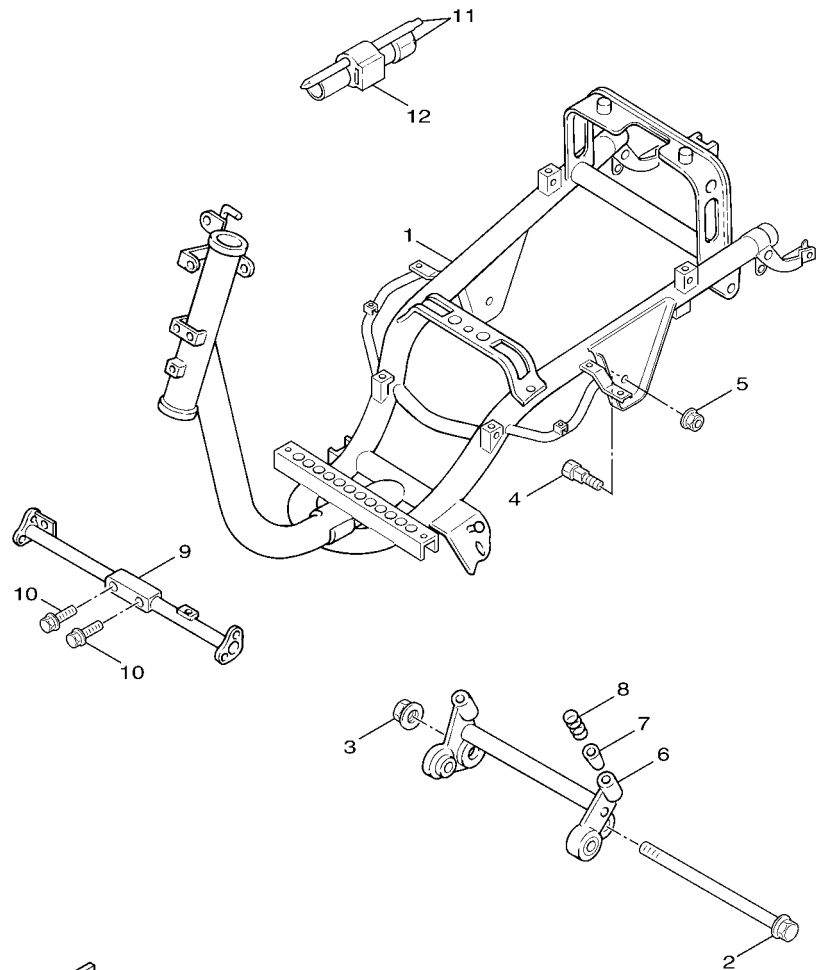

5XB3200-E120

FIG. 12 FRAME

CUADRO

REF. NO.	PART NO. CODIGO Nº	DESCRIPTION DESCRIPCION	5XB4	5XR3	REMARKS OBSERVACIONES
1	5XB-F1110-00-33	FRAME COMP. ARMAZON COMPLETO	1		YB FOR DPBMC,S...
	5XR-F1110-00-33	FRAME COMP. ARMAZON COMPLETO		1	YB FOR DPBMC,S...
2	3XG-F1481-00	BOLT, ENGINE MOUNTING 1 PERNO DE MONTAJE DE MOTOR 1	1	1	YB FOR DPBMC,S...
3	95607-12200	NUT, SELF-LOCKING TUERCA DE AUTO-CIERRE	1	1	YB FOR DPBMC,S...
4	4Y4-F1481-00	BOLT, ENGINE MOUNTING 1 PERNO DE MONTAJE DE MOTOR 1	2	2	
5	90185-10801	NUT, SELF-LOCKING TUERCA AUTOBLOCANTE	2	2	
6	4VP-F1410-30	ENGINE BRACKET COMP. SOPORTE DE MOTOR COMPLETO	1	1	
7	4Y4-F139X-01	DAMPER AMORTIGUADOR	1	1	
8	90501-29517	SPRING, COMPRESSION RESORTE DE COMPRESION	1	1	
9	4VP-F1514-00	STAY, FENDER 2 SOPORTE DE GUARDABARRO 2	1	1	
10	95807-08035	BOLT, FLANGE TORNILLO	2	2	
11	45U-F8100-00	TOOL KIT JUEGO DE HERRAMIENTAS	1	1	
12	23Y-F8175-00	HOLDER, TOOL SOSTEN DE HERRAMIENTAS	1	1	

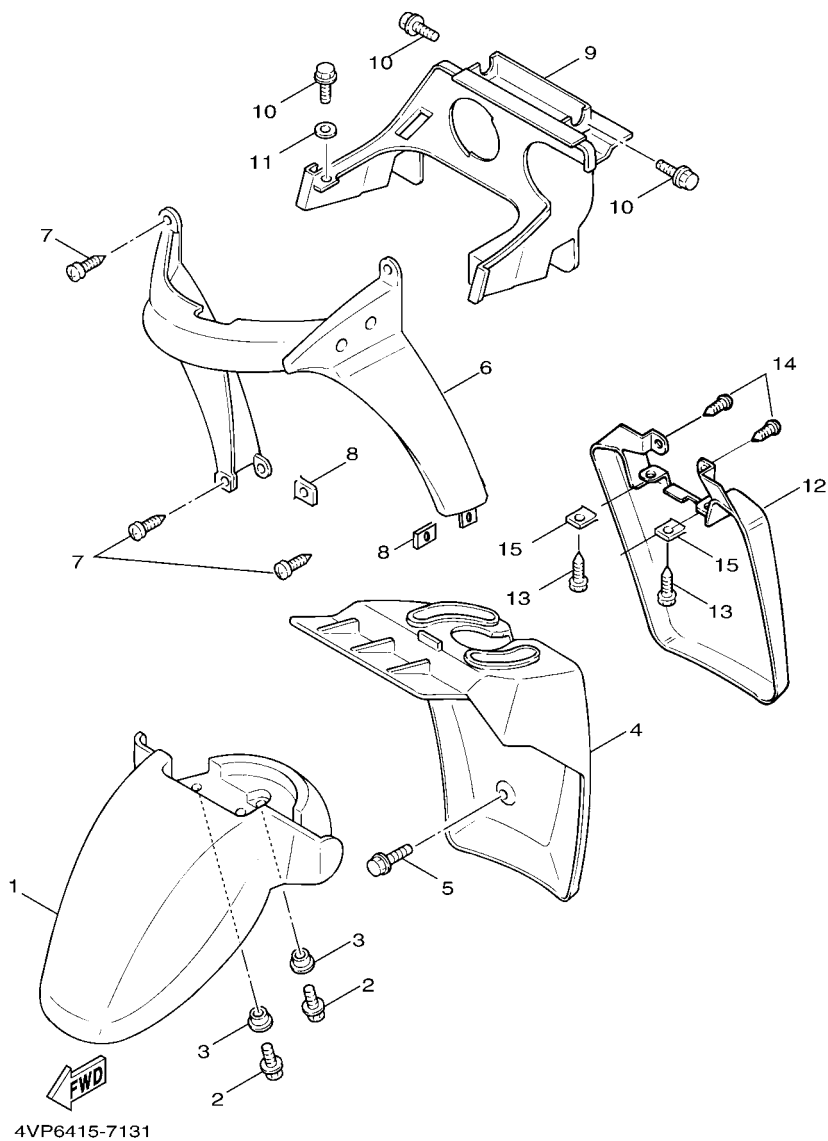

4VP6415-7131

FIG. 13 FENDER

GUARDABARRO

REF. NO.	PART NO. CODIGO Nº	DESCRIPTION DESCRIPCION	5XB4	5XR3	REMARKS OBSERVACIONES
1	4VP-F1511-01	FENDER, FRONT GUARDABARRO DELANTERO	1	1	
2	90119-06821	BOLT, WITH WASHER TORNILLO CON ARANDELA	3	3	
3	90387-068F8	COLLAR ESPACIADOR	3	3	
4	4VP-F1552-00	FENDER, INNER GUARDABARRO	1	1	
5	95807-06012	BOLT, FLANGE TORNILLO	2	2	
6	4VP-F1519-01	MOLE, FENDER MUELLE DE GUARDABARRO	1	1	
7	97707-50016	SCREW, TRUSS HEAD TAPPING TORNILLO	4	4	
8	90183-05807	NUT, SPRING TUERCA DE RESORTE	2	2	
9	4VP-F1629-00	GUARD, MUD GUARDABARRO INFERIOR	1	1	
10	95807-06012	BOLT, FLANGE TORNILLO	4	4	
11	90201-06380	WASHER, PLATE ARANDELA PLANA	2	2	
12	4VP-F1691-01	FLAP CHARNELA	1	1	
13	97707-50012	SCREW, TRUSS HEAD TAPPING TORNILLO	2	2	
14	97707-50016	SCREW, TRUSS HEAD TAPPING TORNILLO	2	2	
15	90183-05807	NUT, SPRING TUERCA DE RESORTE	2	2	



1S54200-F140

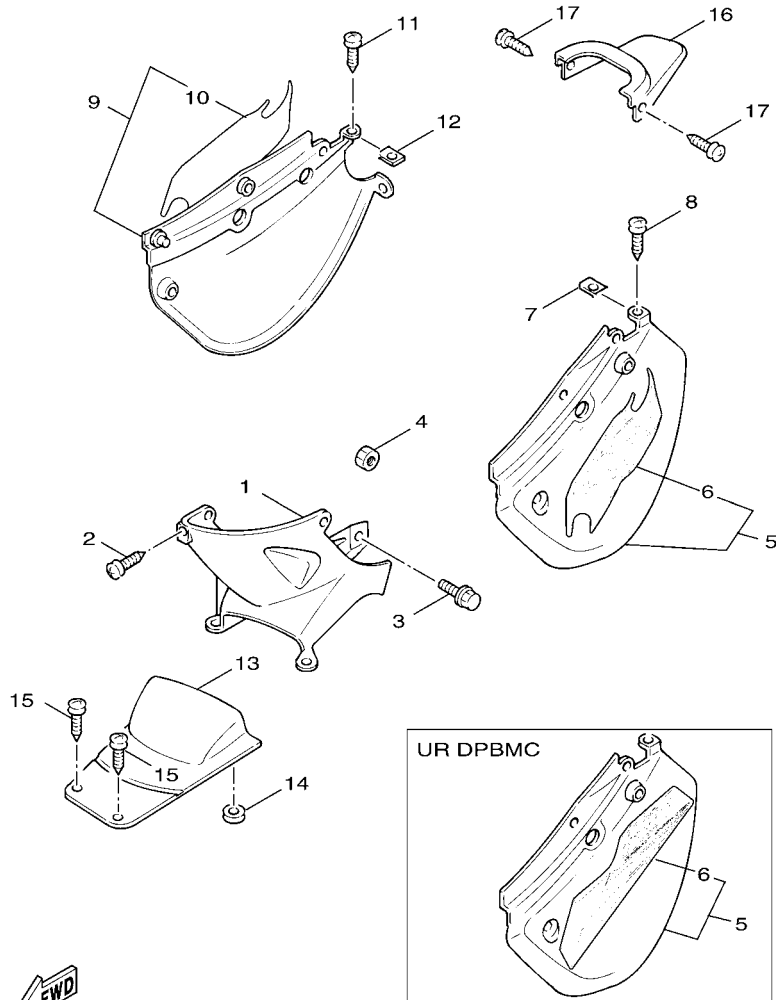

FIG. 14 SIDE COVER

CUBIERTA LATERAL

REF. NO.	PART NO. CODIGO N°	DESCRIPTION DESCRIPCION	5XB4	5XR3	REMARKS OBSERVACIONES
1	4VP-F1711-00	COVER, SIDE 1 CUBIERTA LATERAL 1	1	1	
2	97707-50012	SCREW, TRUSS HEAD TAPPING TORNILLO	3	3	
3	90159-06822	SCREW, WITH WASHER TORNILLO CON VALONA	2	2	
4	2GF-F1535-00	NUT 1 TUERCA 1	2	2	
5	4VP-X2172-C0-P0	COVER, SIDE 2 TAPA LTERAL 2	1	1	UR FOR DPBMC UR FOR DPBMC
---	4VP-X2172-20-P8	COVER, SIDE 2 TAPA LTERAL 2	1	1	UR FOR SMX UR FOR SMX
---	4VP-X2172-20-PA	COVER, SIDE 2 TAPA LTERAL 2	1	1	UR FOR VRS5 UR FOR VRS5
---	4VP-X2172-80-P3	COVER, SIDE 2 TAPA LTERAL 2	1	1	UR FOR VYS2 UR FOR VYS2
6	5XB-F1781-00	.EMBLEM 1 .EMBLEMA 1	1	1	UR FOR DPBMC UR FOR DPBMC
---	5XB-F1783-00	.EMBLEM 3 .EMBLEMA 3	1	1	UR FOR SMX,VYS2 UR FOR SMX,VYS2
---	5XB-F1783-10	.EMBLEM 3 .EMBLEMA 3	1	1	UR FOR VRS5 UR FOR VRS5
7	90183-05807	NUT, SPRING TUERCA DE RESORTE	1	1	
8	97707-50012	SCREW, TRUSS HEAD TAPPING TORNILLO	3	3	
9	4VP-X2173-C0-P0	COVER, SIDE 3 TAPA LATERAL 3	1	1	UR FOR DPBMC UR FOR DPBMC
---	4VP-X2173-20-P8	COVER, SIDE 3 TAPA LATERAL 3	1	1	UR FOR SMX UR FOR SMX
---	4VP-X2173-20-PA	COVER, SIDE 3 TAPA LATERAL 3	1	1	UR FOR VRS5 UR FOR VRS5
---	4VP-X2173-80-P3	COVER, SIDE 3 TAPA LATERAL 3	1	1	UR FOR VYS2 UR FOR VYS2
10	5XB-F1782-00	.EMBLEM 2 .EMBLEMA 2	1	1	UR FOR DPBMC UR FOR DPBMC
---	5XB-F1784-00	.EMBLEM 4 .EMBLEMA 4	1	1	UR FOR SMX,VYS2 UR FOR SMX,VYS2
---	5XB-F1784-10	.EMBLEM 4 .EMBLEMA 4	1	1	UR FOR VRS5 UR FOR VRS5
11	97707-50012	SCREW, TRUSS HEAD TAPPING TORNILLO	3	3	
12	90183-05807	NUT, SPRING TUERCA DE RESORTE	1	1	
13	4VP-F1741-00	COVER, SIDE 4 CUBIERTA LATERAL 4	1	1	
14	90480-16278	GROMMET TAPON	1	1	
15	97707-50012	SCREW, TRUSS HEAD TAPPING TORNILLO	2	2	
16	4VP-F171E-00-P0	COVER, SIDE 5 CUBIERTA LATERAL 5	1	1	UR FOR DPBMC UR FOR DPBMC
---	4VP-F171E-00-P3	COVER, SIDE 5 CUBIERTA LATERAL 5	1	1	UR FOR VYS2 UR FOR VYS2

FIG. 14 SIDE COVER

CUBIERTA LATERAL

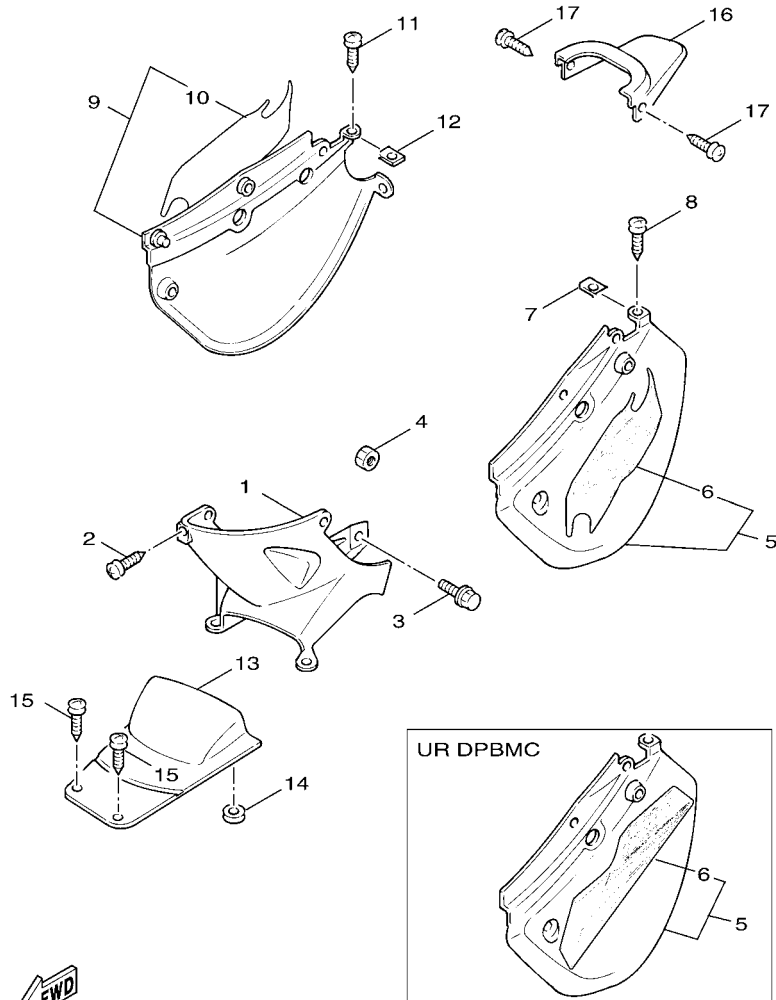

1S54200-F140

REF. NO.	PART NO. CODIGO Nº	DESCRIPTION DESCRIPCION	5XB4	5XR3		REMARKS OBSERVACIONES
16	4VP-F171E-00-P8	COVER, SIDE 5 CUBIERTA LATERAL 5	1	1		UR FOR SMX UR FOR SMX
	4VP-F171E-00-PA	COVER, SIDE 5 CUBIERTA LATERAL 5	1	1		UR FOR VRS5 UR FOR VRS5
17	97707-50012	SCREW, TRUSS HEAD TAPPING TORNILLO	2	2		
<hr/>						
<hr/>						
<hr/>						
<hr/>						
<hr/>						
<hr/>						
<hr/>						
<hr/>						
<hr/>						
<hr/>						
<hr/>						

FIG. 15 OIL TANK

DEPOSITO DE ACEITE

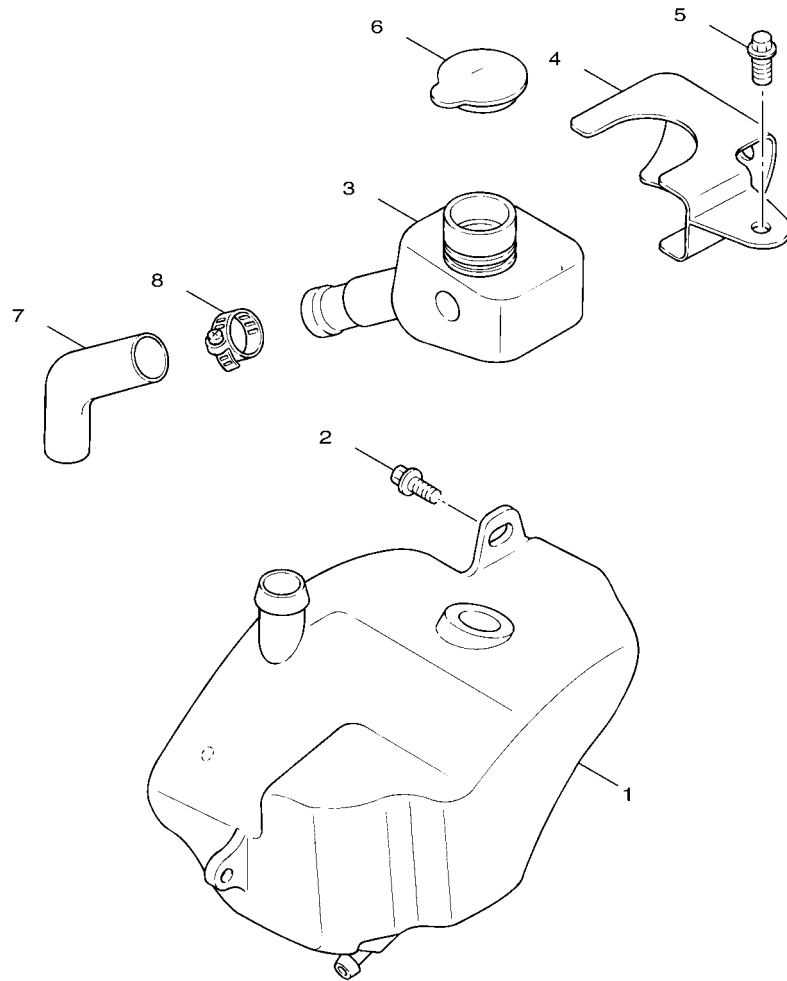

4VP1414-7170

REF. NO.	PART NO. CODIGO N°	DESCRIPTION DESCRIPCION	DEPOSITO DE ACEITE		REMARKS OBSERVACIONES
			5XB4	5XR3	
1	4VP-F1751-00	TANK, OIL DEPOSITO DE ACEITE	1	1	
2	90119-06802	BOLT, WITH WASHER TORNILLO CON ARANDELA	2	2	
3	4VP-F1733-00	SUB TANK, OIL SUBDEPOSITO DE ACEITE	1	1	
4	4VP-F1734-00	HOLDER, OIL SUB TANK SOSTEN SUBDEP.DE ACEITE	1	1	
5	97507-05510	BOLT, WITH WASHER PERNO CON ARANDELA	1	1	
6	4X6-F1771-02	BODY, CAP TAPON DEPOSITO ACEITE	1	1	
7	4VP-F1745-00	PIPE, OIL TANK BREATHER TUBO RESP.DE P.DE ACEITE	1	1	
8	90460-27815	CLAMP, HOSE BRIDA, DE UNION	2	2	

FIG. 16 REAR SUSPENSION

SUSPENSION TRASERO

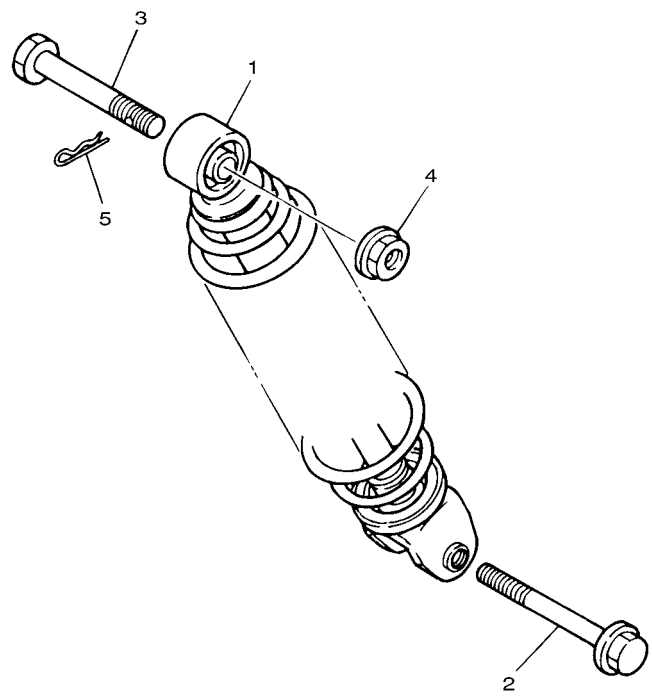

REF. NO.	PART NO. CODIGO Nº	DESCRIPTION DESCRIPCION	5XB4	5XR3		REMARKS OBSERVACIONES
1	5JU-F2210-00	SHOCK ABSORBER ASSY, REAR AMORTIGUADOR TRASERO COMPLETO	1	1		
2	90105-08121	BOLT, FLANGE TORNILLO	1	1		
3	90102-10031	BOLT, WITH HOLE PERNO CON ORIFICIO	1	1		
4	95707-10500	NUT, FLANGE TUERCA DE BRIDA	1	1		
5	90468-12006	CLIP PRESILLA	1	1		

3XG4414-4160

FIG. 17 FRONT FORK

HORQUILLA DELANTERA

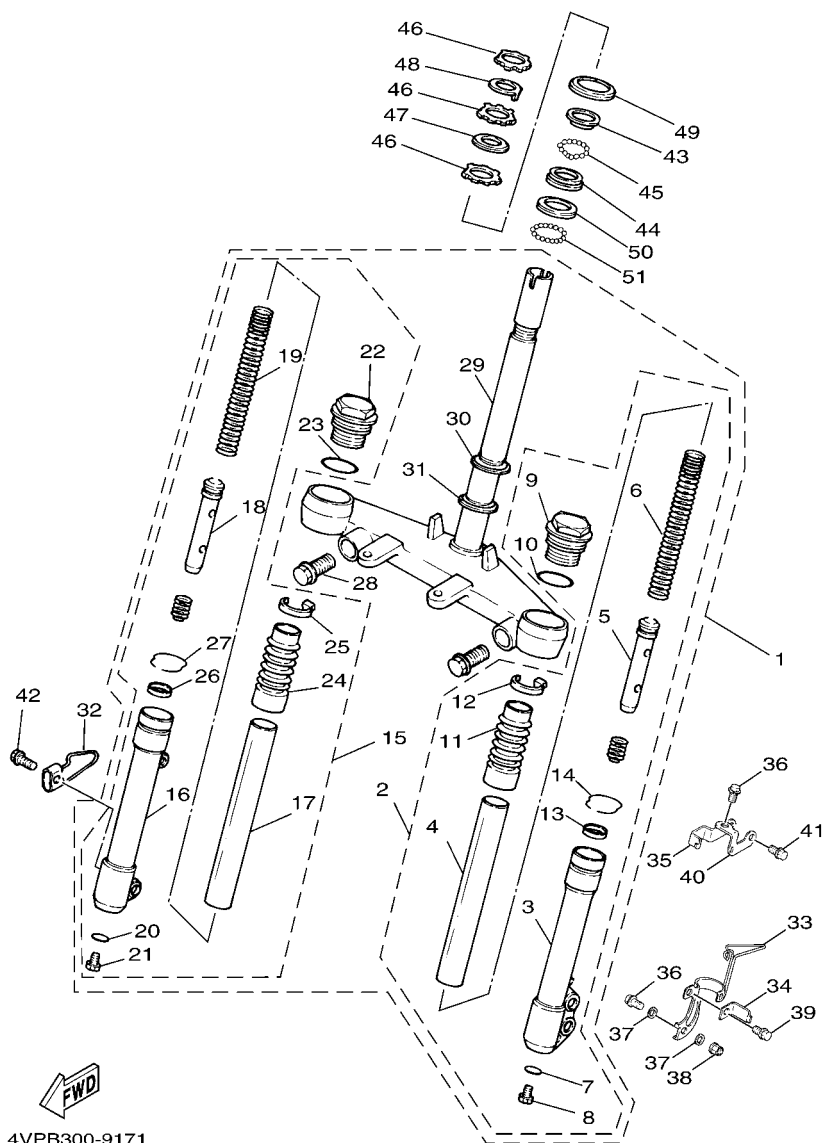

4VPB300-9171

REF. NO.	PART NO. CODIGO Nº	DESCRIPTION DESCRIPCION	5XB4	5XR3	REMARKS OBSERVACIONES
1	4WX-F3100-14-33	FRONT FORK ASSY HORQUILLA DELANTERA COMPLETA	1	1	YB FOR DPBMC,S...
2	4WX-F3102-10-33	..FRONT FORK ASSY (L.H) ..HORQUILLA DELANTERA COMPL.(MI	1	1	
3	4JL-F3126-00-33	..TUBE, OUTER (LEFT) ..TUBO EXTERIOR (IZQUIERDO)	1	1	YB FOR DPBMC,S... YB FOR DPBMC,S...
4	4WX-F3110-00	..INNER TUBE COMP.1 ..TUBO INTERIOR COMPLETO 1	1	1	
5	4WX-F3170-00	..CYLINDER COMP., FRONT FORK ..CILINDRO COMPL DE HORQ DELA	1	1	
6	4WX-F3141-10	..SPRING, FRONT FORK ..RESORTE HORQUILLA DELANT.	1	1	
7	3GF-F3158-00	..GASKET ..EMPAQUE	1	1	
8	3GF-F3181-00	..BOLT, HEXAGON SOCKET HEAD ..TORNILLO CABEZAHEXAGONAL	1	1	
9	4WX-F3154-00	..PLUG, INNER TUBE ..TAPON TUBO INTERIOR	1	1	
10	3GF-F3147-00	..O-RING ..ARO	1	1	
11	4WX-F3191-10	..BOOT ..FUNDA	1	1	
12	4TE-F3192-00	..BAND ..BANDA	1	1	
13	5SU-F3145-00	..OIL SEAL ..RETEN DE ACEITE	1	1	
14	3NW-F3156-00	..CLIP, OIL SEAL ..PRESILLA DEL RETEN DE ACEITE	1	1	
15	4WX-F3103-10-33	..FRONT FORK ASSY (R.H) ..HORQUILLA DELANTERA COMPL.(MD	1	1	
16	4JL-F3136-00-33	..TUBE, OUTER (RIGHT) ..TUBO EXTERIOR	1	1	YB FOR DPBMC,S... YB FOR DPBMC,S...
17	4WX-F3110-00	..INNER TUBE COMP.1 ..TUBO INTERIOR COMPLETO 1	1	1	
18	4WX-F3170-00	..CYLINDER COMP., FRONT FORK ..CILINDRO COMPL DE HORQ DELA	1	1	
19	4WX-F3141-10	..SPRING, FRONT FORK ..RESORTE HORQUILLA DELANT.	1	1	
20	3GF-F3158-00	..GASKET ..EMPAQUE	1	1	
21	3GF-F3181-00	..BOLT, HEXAGON SOCKET HEAD ..TORNILLO CABEZAHEXAGONAL	1	1	
22	4WX-F3154-00	..PLUG, INNER TUBE ..TAPON TUBO INTERIOR	1	1	
23	3GF-F3147-00	..O-RING ..ARO	1	1	
24	4WX-F3191-10	..BOOT ..FUNDA	1	1	
25	4TE-F3192-00	..BAND ..BANDA	1	1	
26	5SU-F3145-00	..OIL SEAL ..RETEN DE ACEITE	1	1	
27	3NW-F3156-00	..CLIP, OIL SEAL ..PRESILLA DEL RETEN DE ACEITE	1	1	

FIG. 17 FRONT FORK

HORQUILLA DELANTERA

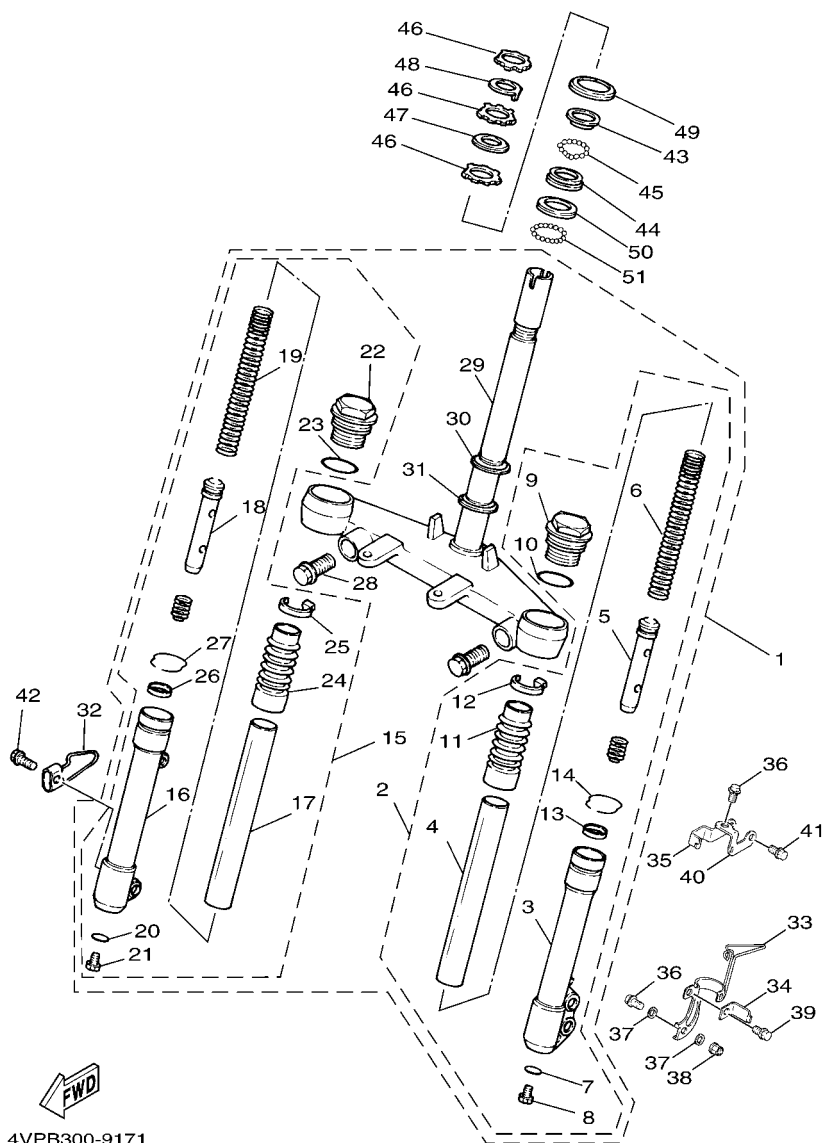

4VPB300-9171

REF. NO.	PART NO. CODIGO Nº	DESCRIPTION DESCRIPCION	5XB4	5XR3	REMARKS OBSERVACIONES
28	3GF-F3346-00	..BOLT 1 ..PERNO 1	2	2	
29	5PJ-F3340-01	..UNDER BRACKET COMP. ..PLATINA INFERIOR COMPLETA	1	1	
30	1MH-F3411-00	..RACE, BALL 1 ..PISTA DE BOLAS 1	1	1	
31	3KW-F3462-00	..SEAL, STEERING ..RETEN DE DIRECCION	1	1	
32	3GF-F3317-00	HOLDER, CABLE SOSTEN DE CABLE	1	1	
33	4VP-F5875-01	HOLDER, BRAKE HOSE 1 SOPORTE DE MANGUERA FRENO 1	1	1	
34	5FA-F5876-00	HOLDER, BRAKE HOSE 2 SOPORTE DE MANGUERA FRENO 2	1	1	
35	4VP-F5876-00	HOLDER, BRAKE HOSE 2 SOPORTE DE MANGUERA FRENO 2	1	1	
36	95817-06020	BOLT, FLANGE TORNILLO	1	1	
37	90201-064J1	WASHER, PLATE ARANDELA PLANA	2	2	
38	95607-06100	NUT, U TUERCA AUTOBLOCANTE	1	1	
39	90119-05062	BOLT, WITH WASHER TORNILLO CON ARANDELA	1	1	
40	5FJ-F5886-00	HOLDER, BRAKE HOSE SOPORTE DE MANGUERA FRENO	1	1	
41	9580L-06012	BOLT, FLANGE TORNILLO	1	1	
42	95807-06010	BOLT, FLANGE TORNILLO	2	2	
43	22F-23411-01	RACE, BALL 1 PISTA DE BOLAS 1	1	1	
44	22F-23412-01	RACE, BALL 2 PISTA DE BOLAS 2	1	1	
45	93503-16003	BALL ESFERA	22	22	
46	90179-25615	NUT TUERCA	3	3	
47	90202-26142	WASHER, PLATE ARANDELA DE PLANA	1	1	
48	4VP-F3418-00	WASHER, SPECIAL ARANDELA ESPECIAL	1	1	
49	4TE-F3416-00	COVER, BALL RACE 2 CUBIERTA DE BASE DE BOLA 2	1	1	
50	156-23412-00	RACE, BALL 2 PISTA DE BOLAS 2	1	1	
51	93501-04011	BALL BOLA	19	19	

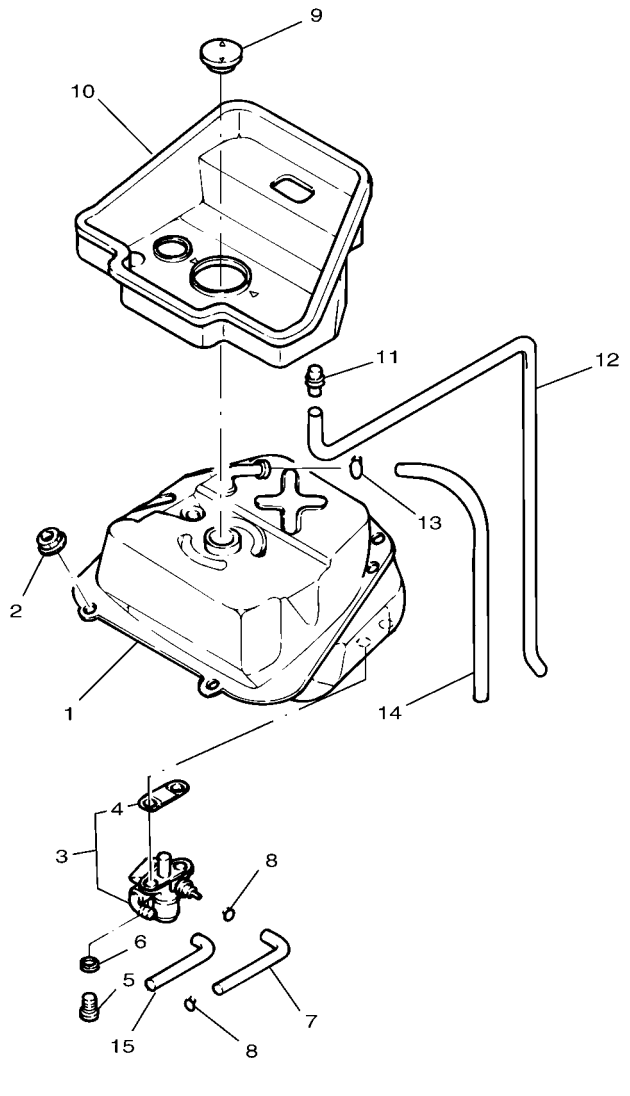

4VP5200-7180

FIG. 18 FUEL TANK

DEPOSITO DE COMBUSTIBLE

REF. NO.	PART NO. CODIGO N°	DESCRIPTION DESCRIPCION	5XB4	5XR3	REMARKS OBSERVACIONES
1	4VP-F4110-10-33	FUEL TANK COMP. DEPOSITO DE COMBUSTIBLE COMP.	1	1	YB FOR DPBMC,S... YB FOR DPBMC,S...
2	95707-06500	NUT, FLANGE TUERCA DE BRIDA	2	2	
3	4CW-F4500-10	FUEL COCK ASSY 1 GRIFO DE COMBUSTIBLE 1	1	1	
4	4CW-F452K-10	.O-RING .ANILLO O	1	1	
5	90149-06011	SCREW TORNILLO DE REGLAJE	2	2	
6	90202-05193	WASHER, PLATE ARANDELA DE PLANA	2	2	
7	4VP-F4311-00	PIPE, FUEL 1 TUBO DE COMBUSTIBLE 1	1	1	
8	90467-09006	CLIP PRESILLA	2	2	
9	4VP-F4610-01	CAP ASSY TAPA COMPLETA	1	1	
10	4VP-F414A-10	COVER, FILLER CUBIERTA DE LLENADOR	1	1	
11	4TE-F1753-00	BOSS, CONNECTOR COPA DE CONECTOR	1	1	
12	91A10-07056	TUBE, FLEXIBLE TUBO	1	1	
13	90467-09006	CLIP PRESILLA	1	1	
14	90445-078A3	HOSE (L460) TUBO (L460)	1	1	
15	90445-105H0	HOSE (L615) TUBO (L615)	1	1	

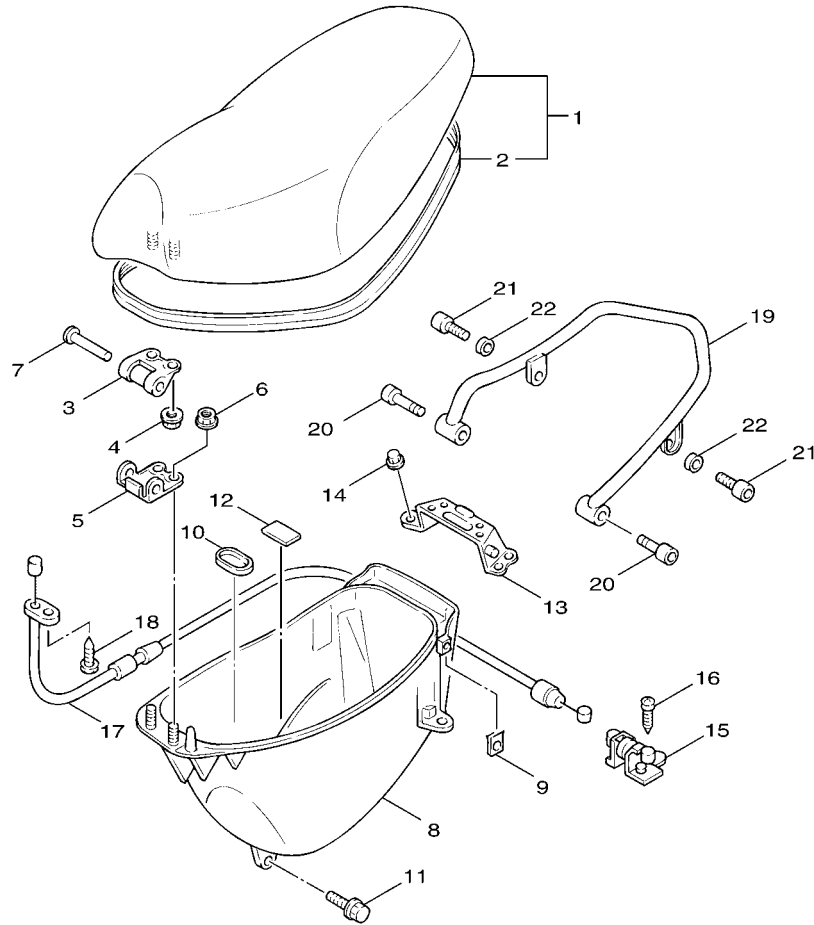

5XB3200-E190

FIG. 19 SEAT

ASIENTO

REF. NO.	PART NO. CODIGO N°	DESCRIPTION DESCRIPCION	5XB4	5XR3	REMARKS OBSERVACIONES
1	5PJ-F4730-00	DOUBLE SEAT ASSY SILLIN DOBLE COMPLETO	1	1	
2	4VP-F475M-00	.SEAL .SELLO	1	1	
3	4CW-F4726-01	HINGE, SEAT HINGE SEAT	1	1	
4	95707-06500	NUT, FLANGE TUERCA DE BRIDA	2	2	
5	4VP-F4726-00	HINGE, SEAT HINGE SEAT	1	1	
6	95707-06500	NUT, FLANGE TUERCA DE BRIDA	2	2	
7	90241-10015	PIN PASADOR	1	1	
8	4VP-F473R-01	BOX 1 CAJA 1	1	1	
9	90183-05807	NUT, SPRING TUERCA DE RESORTE	2	2	
10	4VP-F4742-00	GROMMET ANILLO PROTECTOR	1	1	
11	90109-063F1	BOLT PERNO	4	4	
12	3KW-F139X-00	DAMPER AMORTIGUADOR	1	1	
13	4VP-F4738-10	BRACKET, SEAT SOPORTE DE ASIENTO	1	1	
14	95707-06500	NUT, FLANGE TUERCA DE BRIDA	4	4	
15	4UE-F4780-02	SEAT LOCK ASSY CERRADURA SILLIN COMPLETO	1	1	
16	97007-06016	BOLT PERNO	2	2	
17	4VP-F478E-00	CABLE, SEAT LOCK CABLE	1	1	
18	98507-05010	SCREW, PAN HEAD TORNILLO DE CABEZA CON PLANA	1	1	
19	4VP-F4812-01-1V	HANDLE MANIJA	1	1	FS FOR DPBMC,S...
20	91317-06045	BOLT PERNO	2	2	FS FOR DPBMC,S...
21	91317-06016	BOLT PERNO	2	2	
22	92907-06600	WASHER, PLATE ARANDELA	2	2	

FIG. 20 FRONT WHEEL

RUEDA DELANTERA

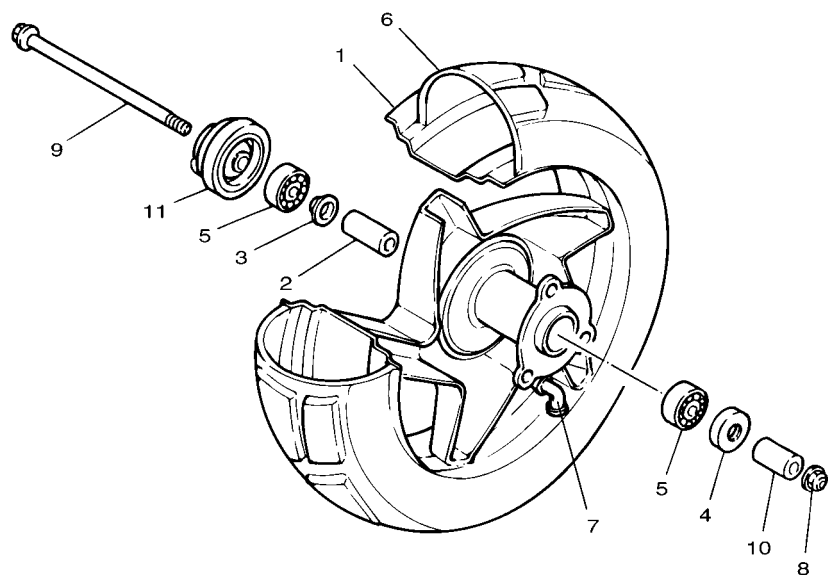

REF. NO.	PART NO. CODIGO Nº	DESCRIPTION DESCRIPCION	5XB4	5XR3	REMARKS OBSERVACIONES
1	4WX-F5180-01-33	WHEEL COMP. RUEDA DELANTERA COMPLETA	1	1	YB FOR DPBMC,S... YB FOR DPBMC,S...
2	4WX-F5183-00	COLLAR, WHEEL COLLAR DE RUEDA	1	1	
3	20A-F5115-00	FLANGE, SPACER 1 BRIDA DE ESPACIADOR 1	1	1	
4	93102-17838	OIL SEAL SELLO ACEITE	1	1	
5	93306-300Y4	BEARING COJINETE	2	2	
6	94112-108S3	TIRE (120/90-10 56J TL) NEUMATICO (120/90-10 56J TL)	1	1	
7	93900-00802	VALVE, RIM VALVULA	1	1	
8	90185-10801	NUT, SELF-LOCKING TUERCA AUTOBLOCANTE	1	1	
9	4WX-F5181-00	AXLE, WHEEL EJE DE LA RUEDA	1	1	
10	90387-104U5	COLLAR ESPACIADOR	1	1	
11	4VP-F5190-10	GEAR UNIT ASSY UNIDAD DE ENGRANAJE COMPLETA	1	1	



4WX1414-7200

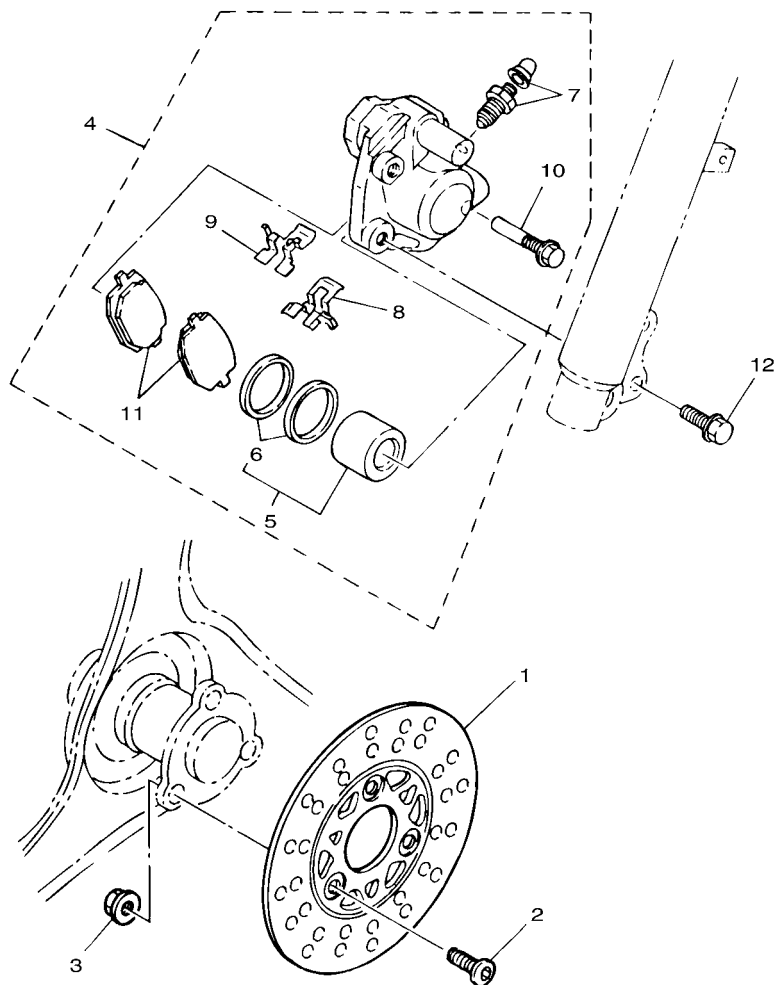

3XG4414-4210

FIG. 21 FRONT BRAKE CALIPER

CALIBRE FRENO DELANTERA

REF. NO.	PART NO. CODIGO Nº	DESCRIPTION DESCRIPCION	5XB4	5XR3	REMARKS OBSERVACIONES
1	3XG-F582T-00	DISC, BRAKE (LEFT) DISCO DE FRENO (IZQUIERDO)	1	1	
2	90110-10811	BOLT, HEXAGON SOCKET HEAD TORNILLO ALLEN	3	3	
3	9570L-10500	NUT, FLANGE TUERCA DE BRIDA	3	3	
4	5JU-F580T-00	CALIPER ASSY (LEFT) CALIBRE COMPLETO (IZQUIERDO)	1	1	
5	3XG-W0057-00	.PISTON ASSY, CALIPER .PISTON COMPLETO PINZA	1	1	
6	3XG-W0047-00	.CALIPER SEAL KIT .JUEGO DE RETENES DE PINZA	1	1	
7	3XG-W0048-00	.BLEED SCREW KIT .CJTO TORNILLO DE PURGA	1	1	
8	3XG-F5919-01	.SUPPORT, PAD .SOPORTE DE PASTILLAS	1	1	
9	3XG-F5919-11	.SUPPORT, PAD .SOPORTE DE PASTILLAS	1	1	
10	3XG-F5926-01	.BOLT .PERNO	1	1	
11	5JU-W0045-00	.BRAKE PAD KIT .JUEGO DE COJIN DE FRENO	1	1	
12	95827-08030	BOLT, FLANGE TORNILLO	2	2	

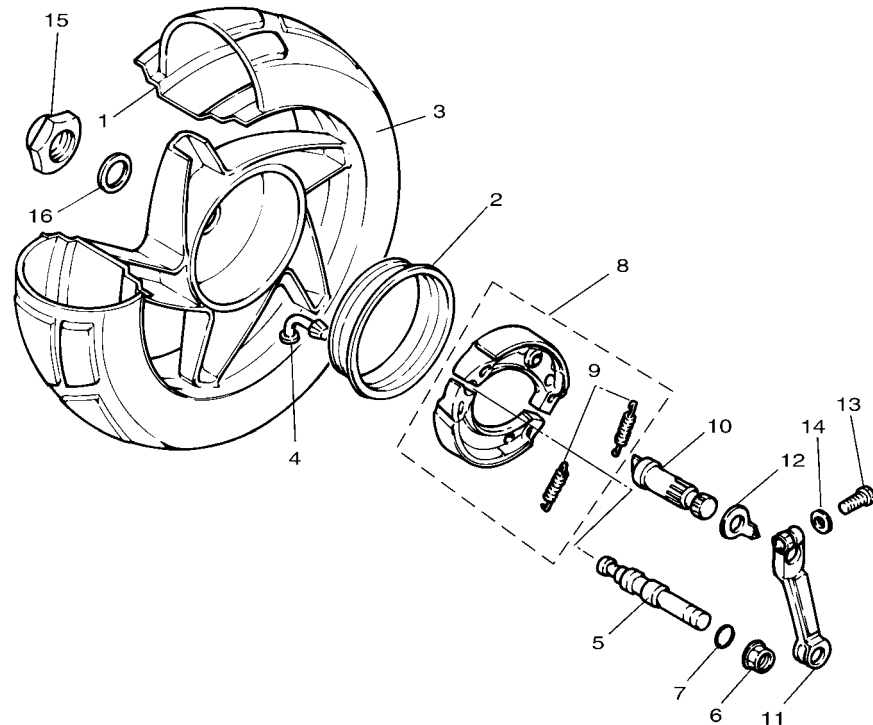



4WX1414-7220

FIG. 22 REAR WHEEL

RUEDA TRASERA

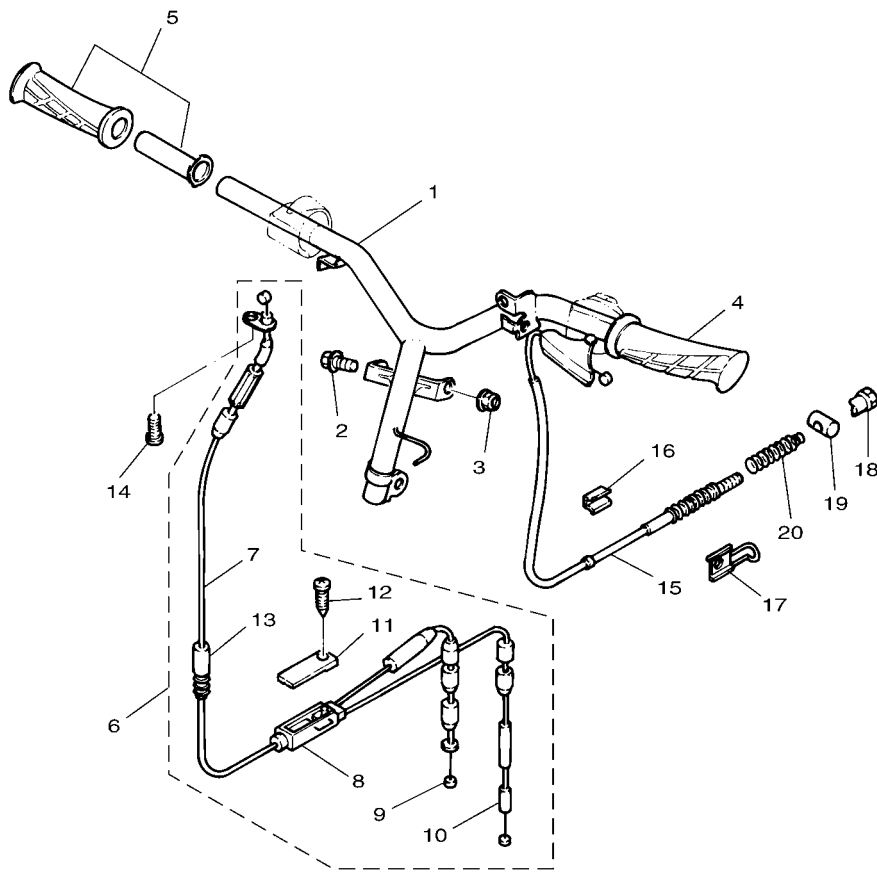
REF. NO.	PART NO. CODIGO Nº	DESCRIPTION DESCRIPCION	5XB4	5XR3	REMARKS OBSERVACIONES
1	4WX-F5390-00-33	REAR WHEEL COMP. RUEDA TRASERA COMPLETA	1	1	YB FOR DPBMC,S... YB FOR DPBMC,S...
2	4WX-F5336-00	RING 2 RESORTE 2	1	1	
3	94113-108S4	TIRE (130/90-10 59J TL) NEUMATICO (130/90-10 59J TL)	1	1	
4	93900-00802	VALVE, RIM VALVULA	1	1	
5	1P3-F5326-00	PIN, PIVOT PASADOR PIVOTE	1	1	
6	95707-10500	NUT, FLANGE TUERCA DE BRIDA	1	1	
7	93210-07890	O-RING ANILLO O	1	1	
8	4WX-X2533-00	BRAKE SHOE SET JUEGO DE ZAPATA DE FRENO	1	1	
9	90506-16447	.SPRING, TENSION .RESORTE DE TENSION	2	2	
10	3UH-F5351-00	CAMSHAFT ARBOL DE LEVAS	1	1	
11	4WX-F5355-00	LEVER, CAMSHAFT PALANCA DE ARBOL DE LEVAS	1	1	
12	4VP-F533A-00	PLATE, INDICATOR PLACA INDICADOR	1	1	
13	90101-06878	BOLT TORNILLO	1	1	
14	90201-142M6	WASHER, PLATE ARANDELA PLANA	1	1	
15	90185-14124	NUT, SELF-LOCKING TUERCA AUTOBLOCANTE	1	1	
16	90201-203E7	WASHER, PLATE ARANDELA PLANA	1	1	



4VP1414-7270

FIG. 23 STEERING HANDLE & CABLE MANILLAR & CABLE

REF. NO.	PART NO. CODIGO Nº	DESCRIPTION DESCRIPCION	5XB4	5XR3		REMARKS OBSERVACIONES
1	4VP-F6110-20	HANDLE COMP. MANUBRIO COMPLETE	1	1		
2	90105-10036	BOLT, FLANGE TORNILLO	1	1		
3	90185-10801	NUT, SELF-LOCKING TUERCA AUTOBLOCANTE	1	1		
4	4VP-F6241-00	GRIP EMPUNADURA	1	1		
5	4VP-F6240-00	GRIP ASSY EMPUNADURA COMPLETA	1	1		
6	4VP-W2620-03	CABLE ASSY CABLE	1	1		
7	4VP-F6311-01	.CABLE, THROTTLE 1 .CABLE DE ACELERADOR 1	1	1		
8	4VP-F6260-02	.CABLE ASSY, THROTTLE & PUMP .CABLE OBTURADOR Y BOMBA	1	1		
9	4VP-F6321-02	.CABLE, PUMP .CABLE DE BOMBA	1	1		
10	4VP-F6312-01	.CABLE, THROTTLE 2 .CABLE DE ACELERADOR 2	1	1		
11	4VP-F6262-00	.CAP, CABLE CONNECTOR .TAPA DE CABLE CONECTOR	1	1		
12	90167-03800	.SCREW, TAPPING .TORNILLO DE ROSCA HEMBRA	1	1		
13	4VP-F6266-00	.BOOT, CYLINDER .FUNDA DE CILINDRO	1	1		
14	98507-05010	SCREW, PAN HEAD TORNILLO DE CABEZA CON PLANA	1	1		
15	4VP-F6351-01	CABLE, BRAKE CABLE DE FRENO	1	1		
16	4VP-F6393-00	HOLDER SOPORTE	1	1		
17	4VP-F637G-00	HOLDER, WIRE SOSTEN, DE CABLE	1	1		
18	90179-06411	NUT TUERCA	1	1		
19	90249-12008	PIN PASADOR	1	1		
20	90501-165J7	SPRING, COMPRESSION RESORTE DE COMPRESION	1	1		

FIG. 24 FRONT MASTER CYLINDER CILINDRO MAESTRO DELANTERO

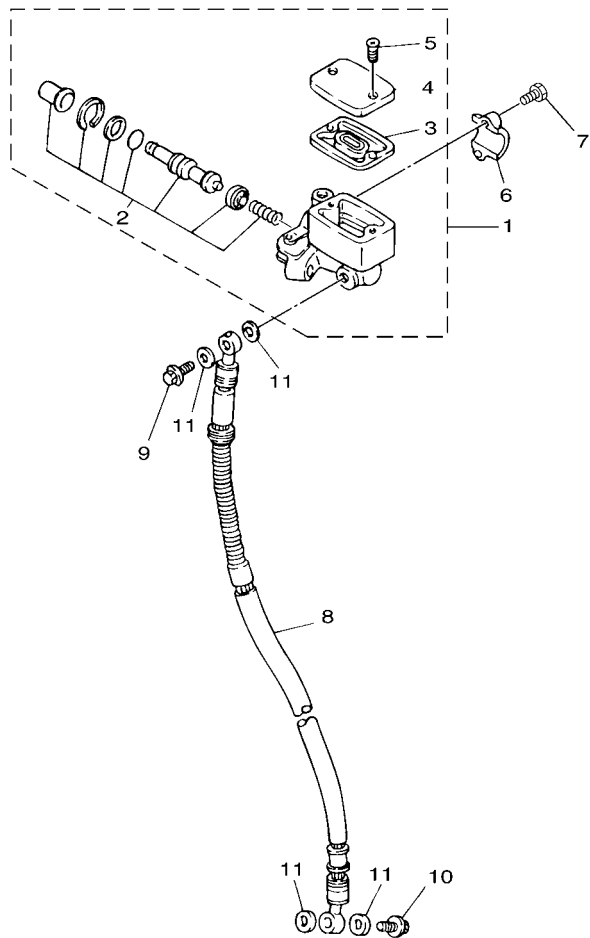

REF. NO.	PART NO. CODIGO N°	DESCRIPTION DESCRIPCION	5XB4	5XR3	REMARKS OBSERVACIONES
1	4JL-F5870-02	MASTER CYLINDER SUB ASSY CILINDRO MAESTRO COMPLETO	1	1	
2	3GF-W0041-00	.CYLINDER KIT, MASTER .JUEGO DE CILINDRO MAESTRO	1	1	
3	3GF-F5854-00	.DIAPHRAGM, RESERVOIR .DIAFRAGMA TANQUE RESERVA	1	1	
4	3GF-F5852-00	.CAP, RESERVOIR .TAPA DE TANQUE DE RESERVA	1	1	
5	98706-04012	.SCREW, FLAT HEAD .TORNILLO DE CABEZA PLANA	2	2	
6	3GF-F5867-00	BRACKET, MASTER CYLINDER SOPORTE DE CILINDRO MAESTRO	1	1	
7	91317-06025	BOLT PERNO	2	2	
8	4VP-F5872-13	HOSE, BRAKE 1 MANGUERA DE FRENO 1	1	1	
9	90401-10805	BOLT, UNION PERNO DE UNION	1	1	
10	90401-10805	BOLT, UNION PERNO DE UNION	1	1	
11	90201-10118	WASHER, PLATE ARANDELA PLANA	4	4	

3XG4414-4241

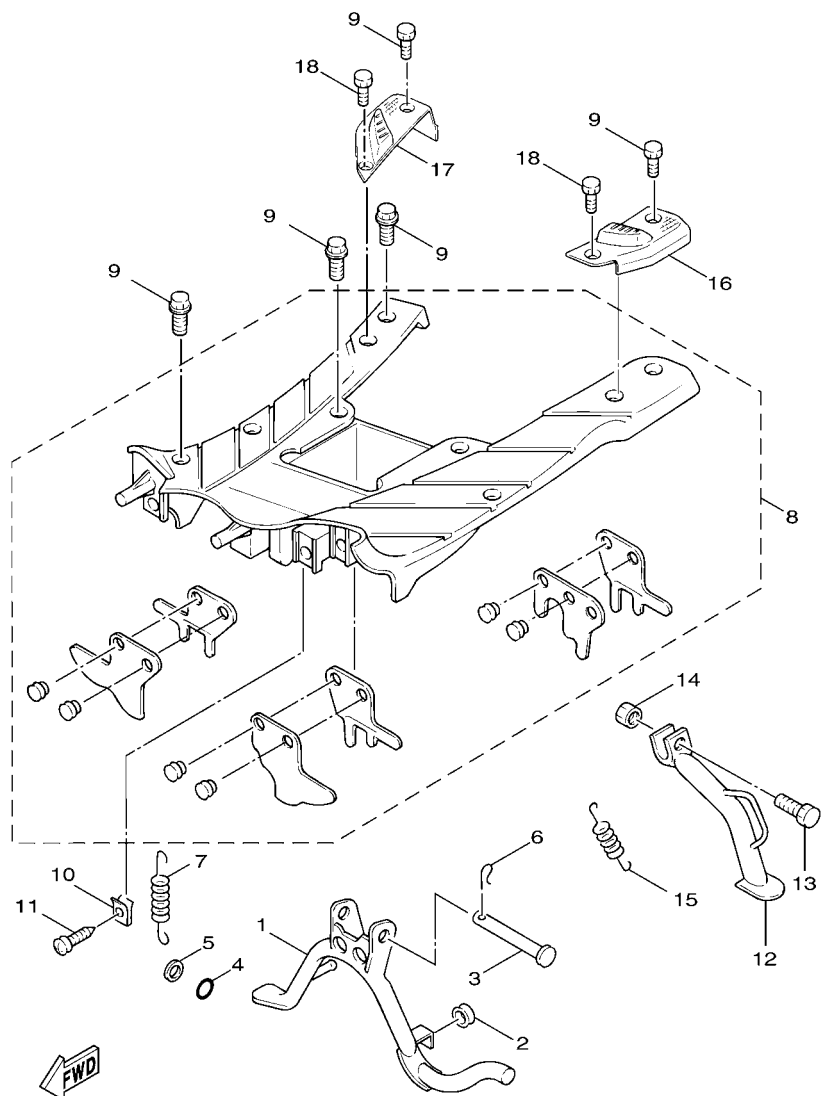

5XB3200-E250

FIG. 25 STAND

SOPORTE

REF. NO.	PART NO. CODIGO Nº	DESCRIPTION DESCRIPCION	5XB4	5XR3	REMARKS OBSERVACIONES
1	4VP-F7111-01	STAND, MAIN PUNTAL PRINCIPAL	1	1	
2	4CW-F7114-00	STOPPER, MAIN STAND TOPE DE PUNTAL PRINCIPAL	1	1	
3	90240-10137	PIN, CLEVIS PASADOR CON HOYO	1	1	
4	93210-108B1	O-RING ANILLO O	1	1	
5	90202-10120	WASHER, PLATE ARANDELA DE PLANA	1	1	
6	90468-12006	CLIP PRESILLA	1	1	
7	90506-32857	SPRING, TENSION RESORTE DE TENSION	1	1	
8	5PJ-XF748-00	FOOTREST BOARD ASSY TABLERO DE APOYAPIE	1	1	
9	90119-06821	BOLT, WITH WASHER TORNILLO CON ARANDELA	6	6	
10	90183-05807	NUT, SPRING TUERCA DE RESORTE	8	8	
11	97707-50016	SCREW, TRUSS HEAD TAPPING TORNILLO	2	2	
12	4VP-F7311-01	STAND, SIDE PUNTAL LATERAL	1	1	
13	90109-10473	BOLT PERNO	1	1	
14	90185-10037	NUT, SELF-LOCKING TUERCA AUTOBLOCANTE	1	1	
15	90506-26805	SPRING, TENSION RESORTE DE TENSION	1	1	
16	5PJ-F7411-00	FOOTREST 1 APOYAPIE 1	1	1	
17	5PJ-F7421-00	FOOTREST 2 APOYAPIE 2	1	1	
18	90119-06079	BOLT, WITH WASHER TORNILLO CON ARANDELA	2	2	

FIG. 26 LEG SHIELD

PATA PROTEGIDA

REF. NO.	PART NO. CODIGO N°	DESCRIPTION DESCRIPCION	5XB4	5XR3	REMARKS OBSERVACIONES
1	4VP-X2831-B0-P0	LEG SHIELD 1 PROTECCION DE PATA 1	1	1	UR FOR DPBMC UR FOR DPBMC
	4VP-X2831-10-P7	LEG SHIELD 1 PROTECCION DE PATA 1	1	1	UR FOR SMX UR FOR SMX
	4VP-X2831-10-P8	LEG SHIELD 1 PROTECCION DE PATA 1	1	1	UR FOR VRS5 UR FOR VRS5
	4VP-X2831-80-P3	LEG SHIELD 1 PROTECCION DE PATA 1	1	1	UR FOR VYS2 UR FOR VYS2
2	5XB-F832B-00	.GRAPHIC15 .EMBLEMA 1	1	1	UR FOR DPBMC UR FOR DPBMC
	5XB-F832K-00	.GRAPHIC 12 .GRAFICO 12	1	1	UR FOR SMX,VYS2 UR FOR SMX,VYS2
	5XB-F832K-10	.GRAPHIC 12 .GRAFICO 12	1	1	UR FOR VRS5 UR FOR VRS5
3	5XB-F832C-00	.GRAPHIC 16 .GRAFICO	1	1	UR FOR DPBMC UR FOR DPBMC
	5XB-F832L-00	.GRAPHIC 13 .GRAFICO 13	1	1	UR FOR SMX,VYS2 UR FOR SMX,VYS2
	5XB-F832L-10	.GRAPHIC 13 .GRAFICO 13	1	1	UR FOR VRS5 UR FOR VRS5
4	4TH-F152A-E0	.EMBLEM 3 .EMBLEMA 3	1	1	UR FOR DPBMC UR FOR DPBMC
	5XB-F152A-00	.EMBLEM 3 .EMBLEMA 3	1	1	UR FOR SMX UR FOR SMX
	5XB-F152A-20	.EMBLEM 3 .EMBLEMA 3	1	1	UR FOR VRS5 UR FOR VRS5
	5XB-F152A-30	.EMBLEM 3 .EMBLEMA 3	1	1	UR FOR VYS2 UR FOR VYS2
5	4VP-F834V-00	PROTECTOR 1 PROTECTOR 1	1	1	
6	90159-06812	SCREW, WITH WASHER TORNILLO CON VALONA	1	1	
7	4VP-F8300-01	LEG SHIELD ASSY PROTECCION DE PATA COMPLETA	1	1	
8	5FM-F8349-00	CAP TAPA	1	1	
9	4JK-F1568-00	LABEL, WARNING ETIQUETA DE PRECAUCION	1	1	
10	97707-50016	SCREW, TRUSS HEAD TAPPING TORNILLO	4	4	
11	4VP-F8385-11	COVER, LOWER CUBIERTA INFERIOR	1	1	
12	97707-50016	SCREW, TRUSS HEAD TAPPING TORNILLO	6	6	
13	3GF-F6199-00	PLUG, BLIND TAPON	4	4	
14	4VP-F840K-00-1V	GUARD COMP. ACCESORIO	1	1	FS FOR DPBMC,S... FS FOR DPBMC,S...
15	95027-06020	BOLT, FLANGE PERNO, DE BRIDA	4	4	
16	4VP-F1535-00	NUT 1 TUERCA 1	4	4	
17	90338-16148	PLUG TAPON	2	2	

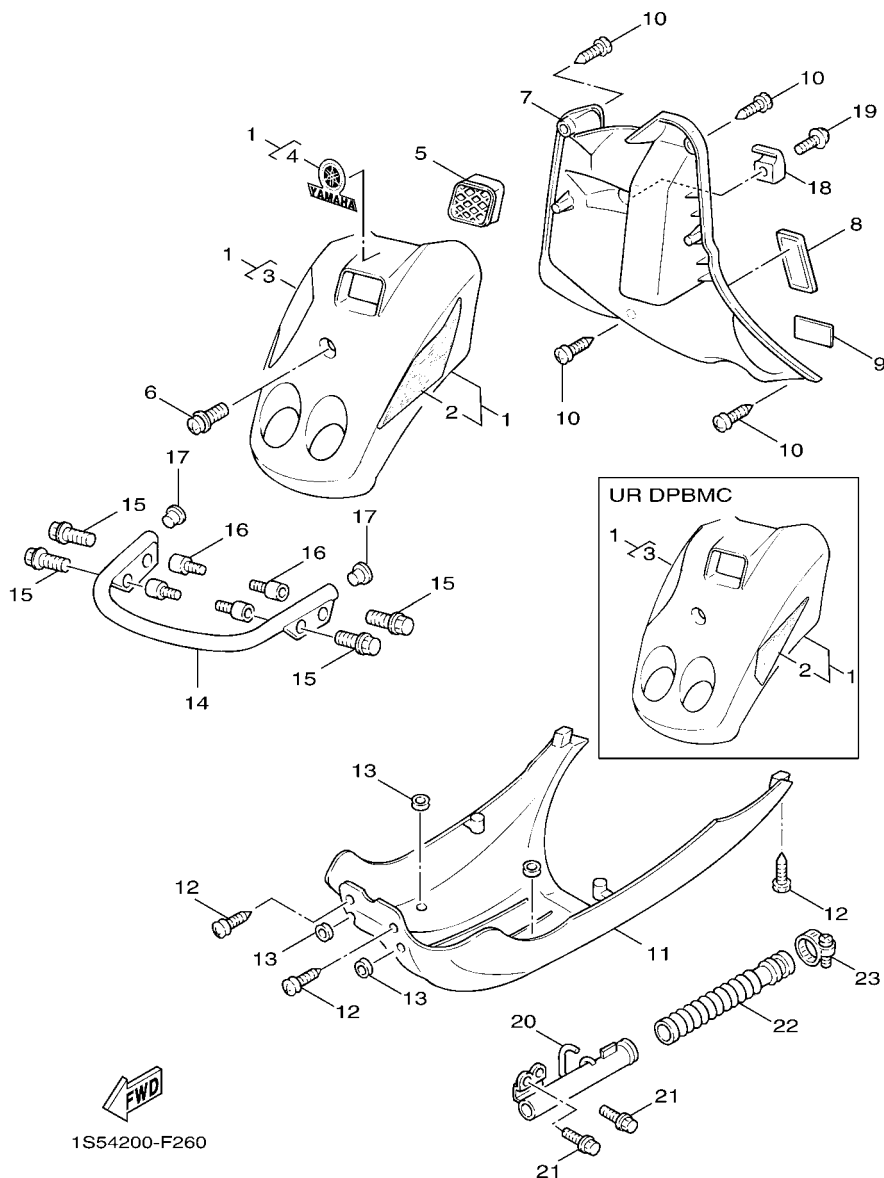

FIG. 26 LEG SHIELD

PATA PROTEGIDA

REF. NO.	PART NO. CODIGO Nº	DESCRIPTION DESCRIPCION	5XB4	5XR3	REMARKS OBSERVACIONES
18	4VP-F8257-01	HOOK 1 GANCHO 1	1	1	
19	90159-06811	SCREW, WITH WASHER TORNILLO CON VALONA	1	1	
20	4VP-F838K-00	BOX 1 CAJA 1	1	1	
21	95807-06014	BOLT, FLANGE TORNILLO	2	2	
22	4VP-F1851-00	DUCT, COOLER CONDUCTO DE ENFRIADOR	1	1	
23	90460-35260	CLAMP, HOSE BRIDA, DE UNION	2	2	

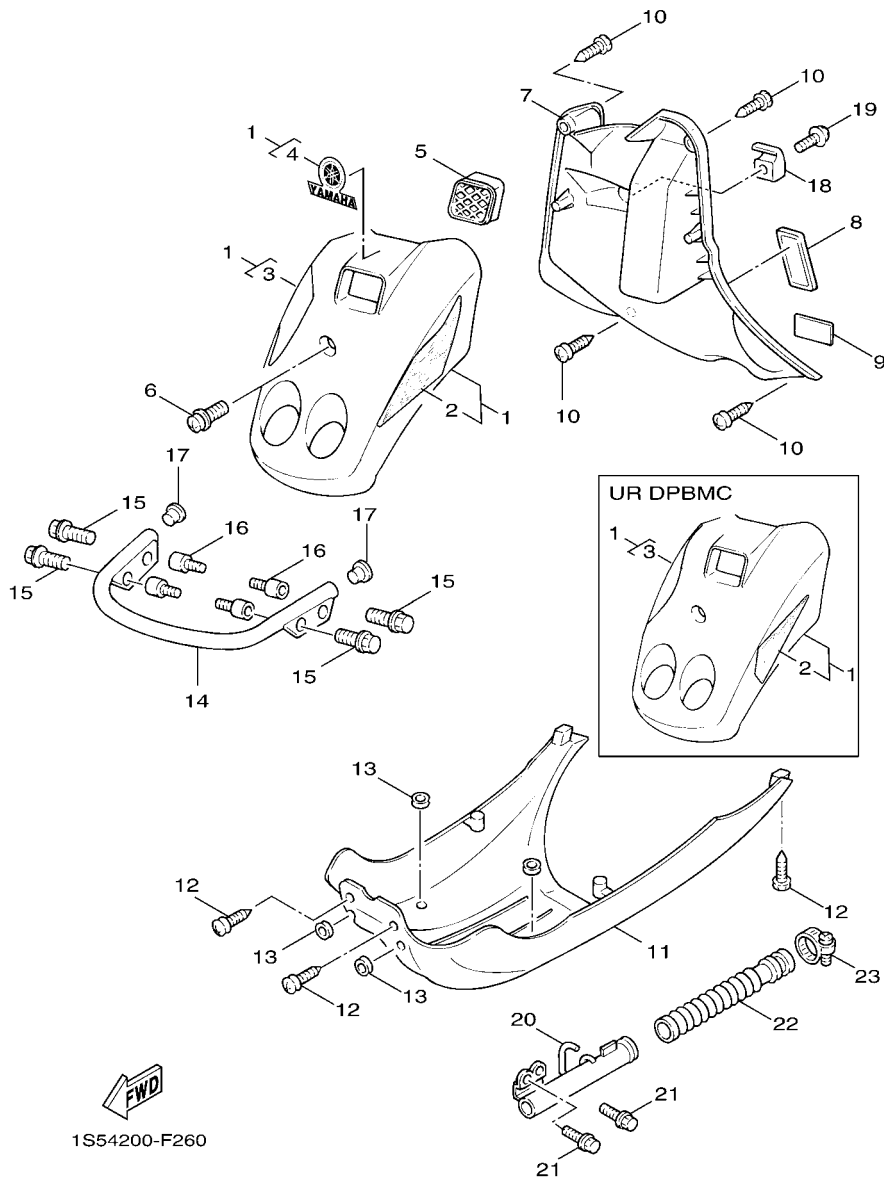
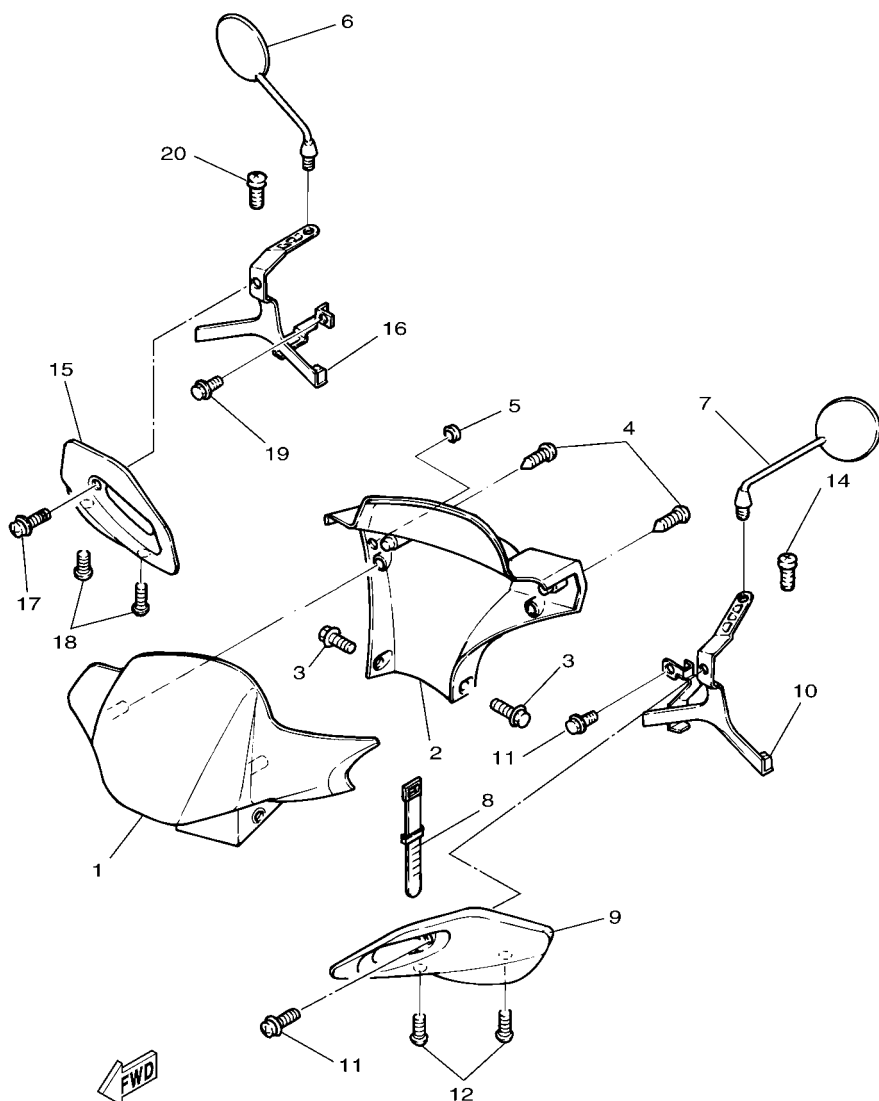

FIG. 27 COWLING 1

BOVEDA 1

REF. NO.	PART NO. CODIGO Nº	DESCRIPTION DESCRIPCION	5XB4	5XR3	REMARKS OBSERVACIONES
1	4VP-F6143-00-P0	COVER, HANDLEBAR UPPER 1 CUBIERTA DE MANUBRIO SUPERIOR1	1	1	UR FOR DPBMC UR FOR DPBMC
	4VP-F6143-00-P3	COVER, HANDLEBAR UPPER 1 CUBIERTA DE MANUBRIO SUPERIOR1	1	1	UR FOR VYS2 UR FOR VYS2
	4VP-F6143-00-P8	COVER, HANDLEBAR UPPER 1 CUBIERTA DE MANUBRIO SUPERIOR1	1	1	UR FOR SMX UR FOR SMX
	4VP-F6143-00-PA	COVER, HANDLEBAR UPPER 1 CUBIERTA DE MANUBRIO SUPERIOR1	1	1	UR FOR VRS5 UR FOR VRS5
2	4VP-F6145-00	COVER, HANDLEBAR UPPER 2 CUBIERTA DE MANUBRIO SUPERIOR2	1	1	
3	90159-05831	SCREW, WITH WASHER TORNILLO CON VALONA	2	2	
4	90160-05803	SCREW, ROUND TAPPING TORNILLO REDONDO ROSCA HEMBRA	2	2	
5	3GF-F6199-00	PLUG, BLIND TAPON	1	1	
6	4VP-F6290-00	REAR VIEW MIRROR ASSY (RIGHT) ESPEJO COMPLETO (DERECHO)	1	1	
7	4VP-F6280-00	REAR VIEW MIRROR ASSY (LEFT) ESPEJO COMPLETO (IZQUIERDO)	1	1	
8	90465-13275	CLAMP BRIDA	1	1	
9	4VP-F6141-00	GUARD, BRUSH 1 GUARDA ESCOBILLA 1	1	1	
10	4VP-F612M-01	BRACKET 4 SOPORTE 4	1	1	
11	90159-05820	SCREW, WITH WASHER TORNILLO CON VALONA	1	1	
12	90149-05821	SCREW TORNILLO DE REGLAJE	2	2	
13	95807-06012	BOLT, FLANGE TORNILLO	1	1	
14	95807-08014	BOLT, FLANGE TORNILLO	1	1	
15	4VP-F6142-00	GUARD, BRUSH 2 GUARDA ESCOBILLA 2	1	1	
16	4VP-F612N-01	BRACKET 5 SOPORTE 5	1	1	
17	90159-05820	SCREW, WITH WASHER TORNILLO CON VALONA	1	1	
18	90149-05821	SCREW TORNILLO DE REGLAJE	2	2	
19	95807-06012	BOLT, FLANGE TORNILLO	1	1	
20	4VP-F6225-00	BOLT, HANDLE PERNO DE MANUBRIO	1	1	



4VPA414-9350

FIG. 28 GENERATOR

GENERADOR

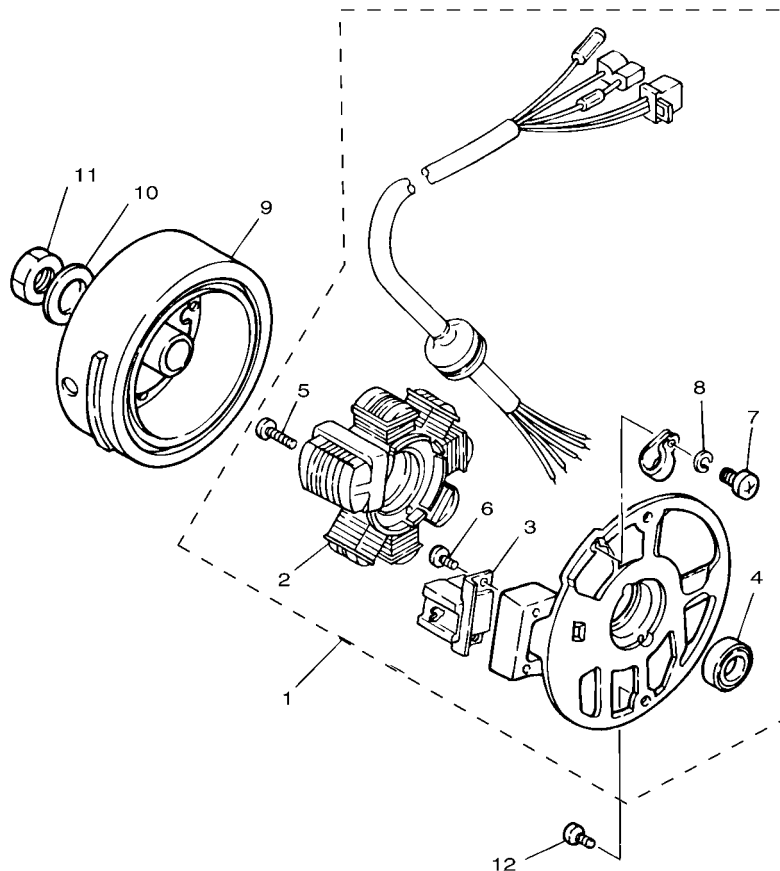

REF. NO.	PART NO. CODIGO Nº	DESCRIPTION DESCRIPCION	5XB4	5XR3	REMARKS OBSERVACIONES
1	3XG-H5560-00	BASE ASSY CONJUNTO BASE	1	1	
2	3GF-H1403-V0	.STATORCOMP. .ESTATOR COMPLETO	1	1	
3	3GF-H5580-V0	.COIL, PULSER .BOBINA DE PULSACION	1	1	
4	93104-19097	.OIL SEAL .SELLO ACEITE	1	1	
5	98501-05020	.SCREW, PAN HEAD .TORNILLO DE CABEZA CRUZADA	2	2	
6	98501-05010	.SCREW, PAN HEAD .TORNILLO DE CABEZA CRUZADA	2	2	
7	98501-04008	.SCREW, PAN HEAD .TORNILLO DE CABEZA CRUZADA	1	1	
8	92901-04100	.WASHER, SPRING .ARANDELA PLANA	1	1	
9	4KX-H5550-00	ROTOR ASSY ROTOR COMPLETO	1	1	
10	92907-12600	WASHER, PLATE ARANDELA	1	1	
11	95307-12600	NUT TUERCA	1	1	
12	98507-06016	SCREW, PAN HEAD TORNILLO DE CABEZA CON PLANA	2	2	



3XG4414-4280

FIG. 29 STARTING MOTOR

MOTOR DE ARRANQUE

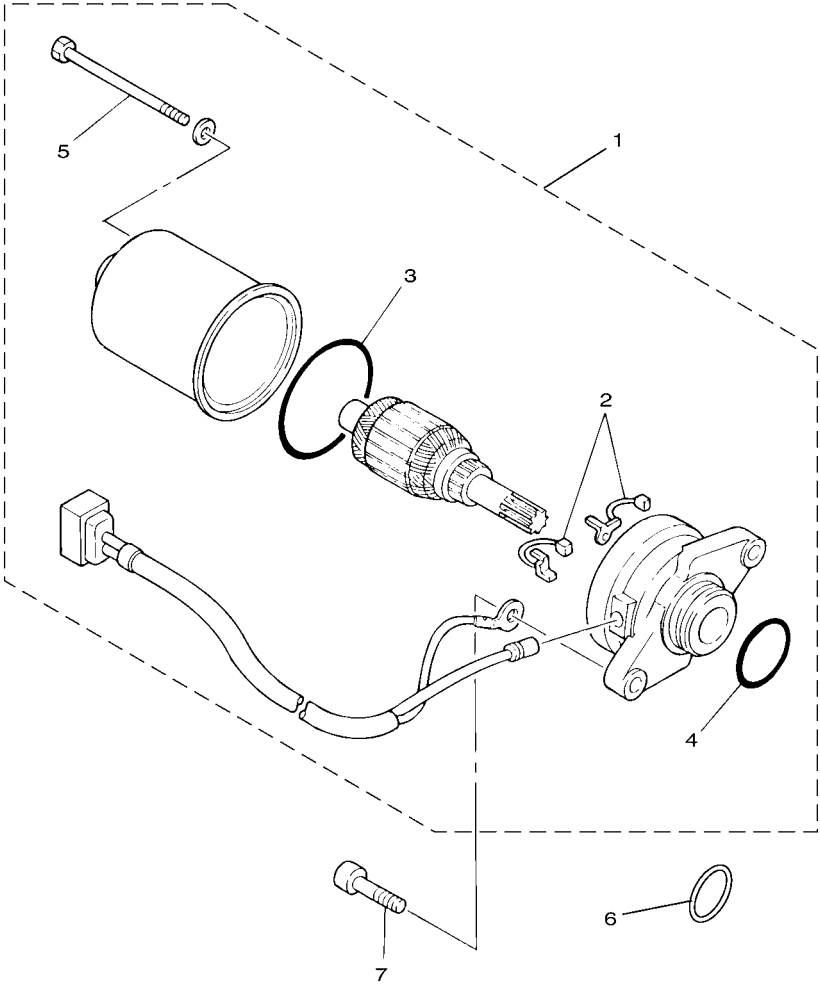

4VP1414-7371

REF. NO.	PART NO. CODIGO Nº	DESCRIPTION DESCRIPCION	5XB4	5XR3	REMARKS OBSERVACIONES
1	4VP-H1800-20	STARTING MOTOR ASSY MOTOR DE ARRANQUE COMPLETO	1	1	
2	4DM-H1801-00	.BRUSH SET .JUEGO DE ESCOBILLA	1	1	
3	93210-44678	.O-RING .ANILLO O	1	1	
4	93210-23614	.O-RING .ANILLO O	1	1	
5	3NW-H1828-V0	.BOLT 2 .TORNILLO DE EMPUJE 2	2	2	
6	90202-26166	WASHER, PLATE ARANDELA DE PLANA	1	1	
7	91318-06020	BOLT TORNILLO	2	2	

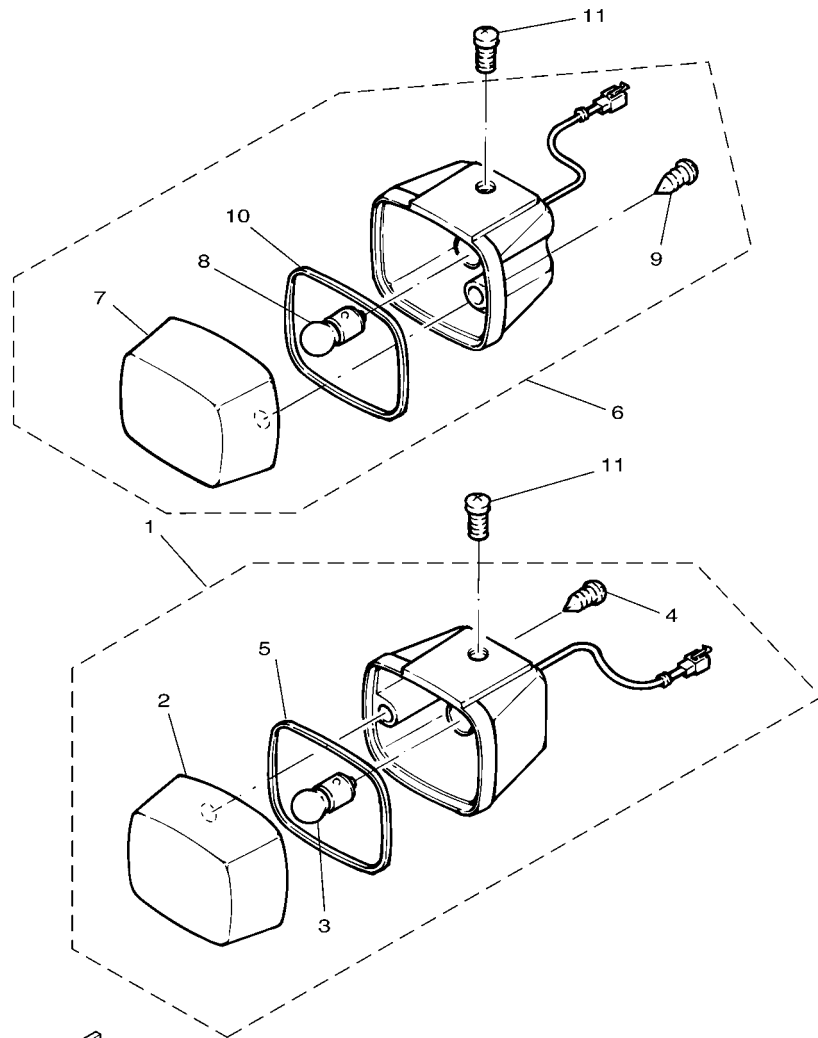

4VP1414-7380

FIG. 30 FLASHER LIGHT

LUZ DE DESTELLADOR

REF. NO.	PART NO. CODIGO Nº	DESCRIPTION DESCRIPCION	5XB4	5XR3	REMARKS OBSERVACIONES
1	4VP-H3310-00	FRONT FLASHER LIGHT ASSY 1 DESTELLADOR DE LUZ DELANT.	1	1	
2	4VP-H3312-00	.LENS, FLASHER .LENTE DE DESTELLADOR	1	1	
3	4VP-H3311-00	.BULB, FLASHER .BOMBILLA DE DESTELLADOR	1	1	
4	97707-40610	.SCREW, TAPPING .TORNILLO ROSCA HEMBRA	1	1	
5	4VP-H3313-00	.GASKET, FLASHER LENS .EMPAQUE DE LENTE DESTELLADOR	1	1	
6	4VP-H3320-00	FRONT FLASHER LIGHT ASSY 2 DESTELLADOR DE LUZ DELANT.	1	1	
7	4VP-H3322-00	.LENS, FLASHER 2 .LENTE DE INTERMITENTE 2	1	1	
8	4VP-H3311-00	.BULB, FLASHER .BOMBILLA DE DESTELLADOR	1	1	
9	97707-40610	.SCREW, TAPPING .TORNILLO ROSCA HEMBRA	1	1	
10	4VP-H3313-00	.GASKET, FLASHER LENS .EMPAQUE DE LENTE DESTELLADOR	1	1	
11	98507-05010	SCREW, PAN HEAD TORNILLO DE CABEZA CON PLANA	2	2	

FIG. 31 METER

MEDIDOR

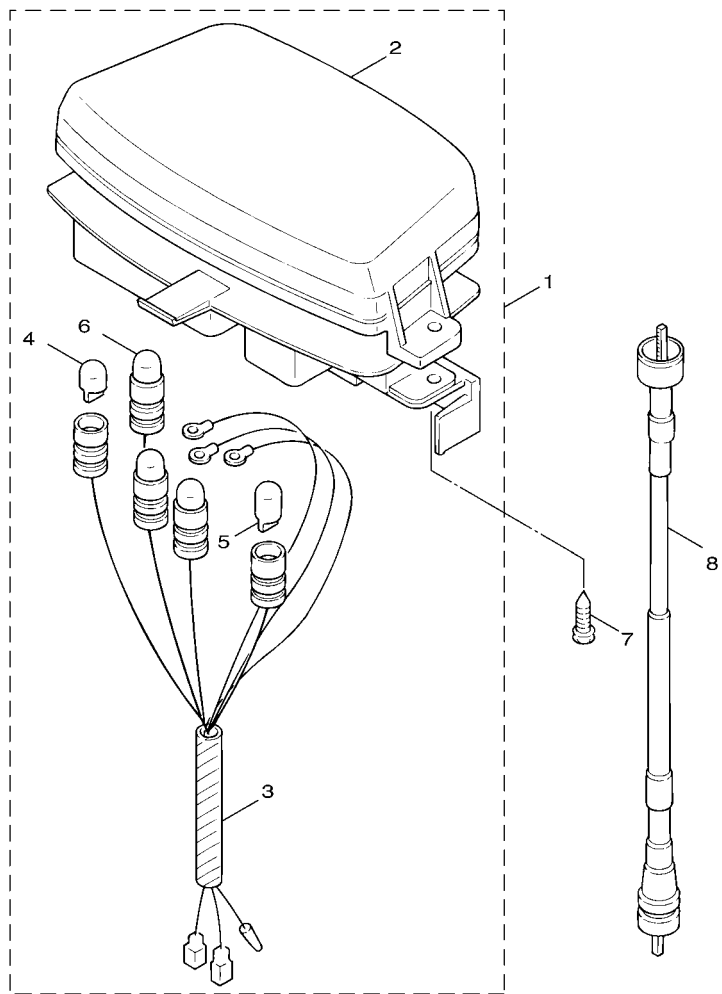



4VP1414-7391

REF. NO.	PART NO. CODIGO N°	DESCRIPTION DESCRIPCION	5XB4	5XR3			REMARKS OBSERVACIONES
1	4VP-H3510-00	SPEEDOMETER ASSY VELOCIMETRO COMPL.	1	1			
2	4VP-H353K-00	.GLASS PLATE .CUBIERTA DE MEDIDOR	1	1			
3	4VP-H3509-00	.SOCKET CORD ASSY .ENCASTRE DE CABLE COMPLETO	1	1			
4	3GF-H3517-00	.BULB (12V-1.7W) .AMPOLLETA	3	3			
5	4VP-H3517-00	.BULB (12V 3.4W) .AMPOLLETA (12V-3.4W)	1	1			
6	4TE-H3518-00	.BULB, METER (12V 1.7W) .AMPOLLETA DE MEDIDOR (1.7W)	1	1			
7	97707-50016	SCREW, TRUSS HEAD TAPPING TORNILLO	2	2			
8	4VP-H3550-03	SPEEDOMETER CABLE ASSY CABLE DE VELOCIMETRO COMPLETO	1	1			

FIG. 32 HEADLIGHT

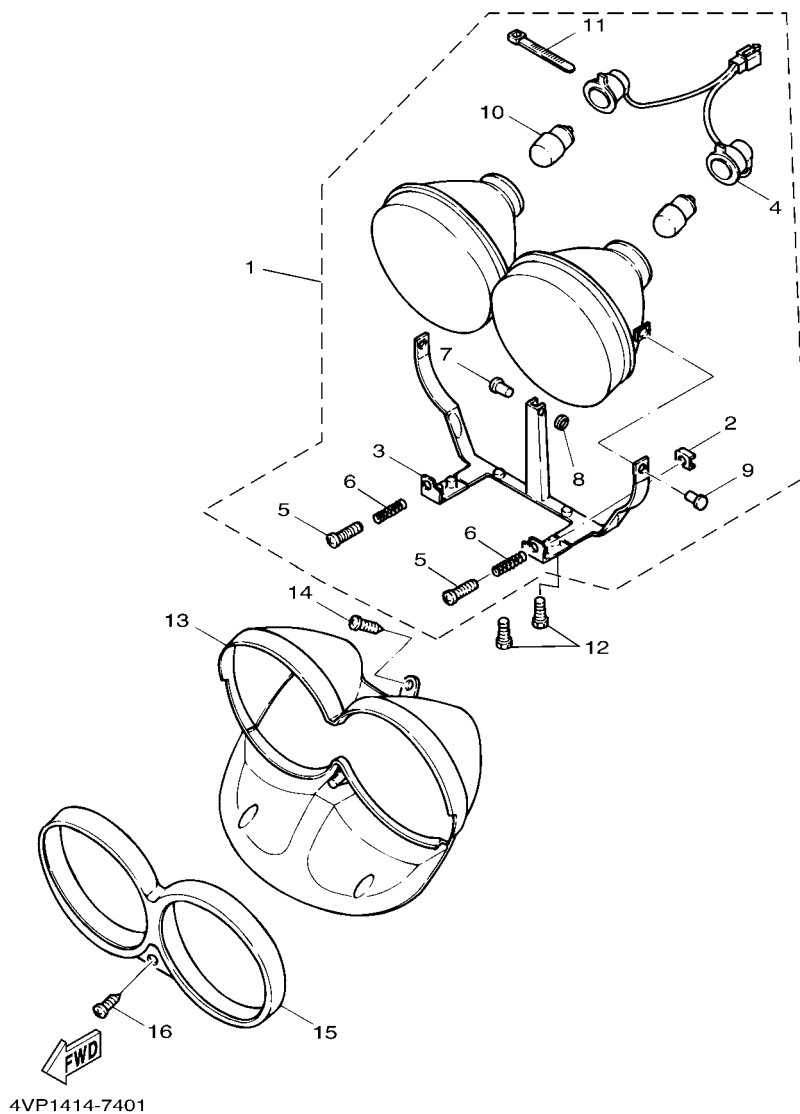
FARO DELANTERO



REF. NO.	PART NO. CODIGO Nº	DESCRIPTION DESCRIPCION	5XB4	5XR3	REMARKS OBSERVACIONES
1	4VP-H430A-00	HEADLIGHT UNIT ASSY UNIDAD DE FARO DELANTERO COMPL	1	1	
2	4VP-H4317-00	.NUT .TUERCA	2	2	
3	4VP-H4318-00	.STAY, HEADLIGHT 1 .APOYO DE FARO DELANTERO 1	1	1	
4	4VP-H4359-00	.CORD, HEADLIGHT .CABLE DE FARO DELANTERO	1	1	
5	4VP-H4331-00	.SCREW, RIM ADJUSTING .TORNILLO DE AJUSTE DE ARO	2	2	
6	4VP-H4332-00	.SPRING, SCREW .RESORTE DE TORNILLO	2	2	
7	4VP-H431V-00	.PIN .PASADOR	1	1	
8	4VP-H4198-00	.CLIP, COVER FITTING .PRESILLA, CUBIERTA FIXATION	1	1	
9	4VP-H4337-00	.BOLT, SPECIAL .PERNO ESPECIAL	2	2	
10	3UH-H4314-10	.BULB, HEADLIGHT (12V-20/20W) .BOMBILLA DE FARO DELANTERO	2	2	
11	4VP-H4351-00	.CLAMP, CORD .GRAMPA DE CABLE	1	1	
12	95807-06016	BOLT, FLANGE TORNILLO	4	4	
13	4VP-H4144-00	COVER, HEADLIGHT CUBIERTA FARO DELANTERO	1	1	
14	97707-50012	SCREW, TRUSS HEAD TAPPING TORNILLO	1	1	
15	4VP-H4169-00	GUARD, HEADLIGHT PROTECCION DE FARO DELANTERO	1	1	
16	90163-05800	SCREW, TAPPING TORNILLO ROSCA HEMBRA	1	1	

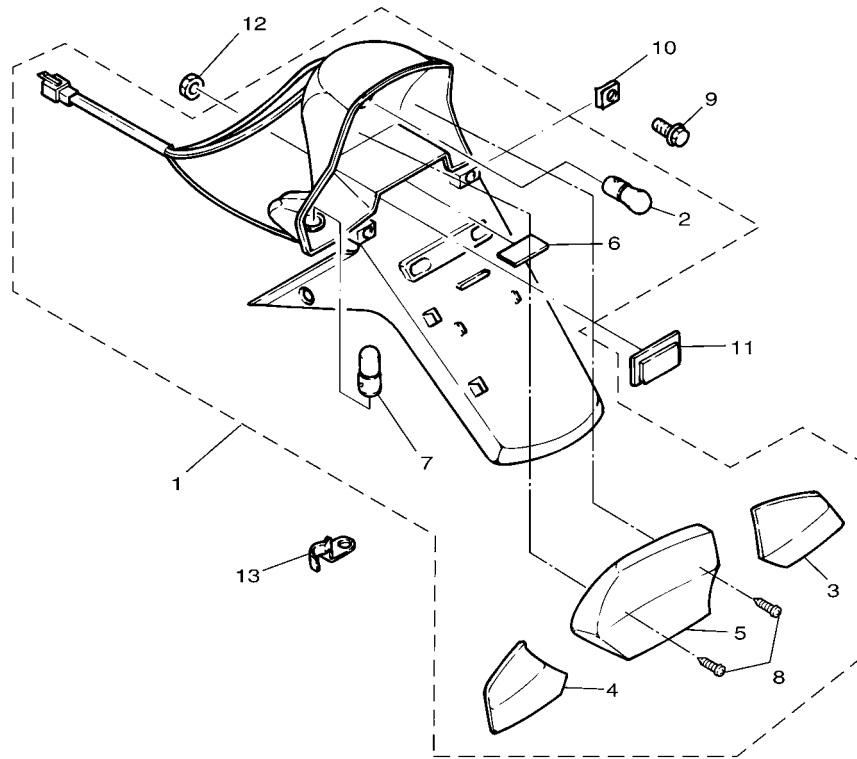

4VP5200-7330

FIG. 33 TAILLIGHT

LUZ DE COLA

REF. NO.	PART NO. CODIGO N°	DESCRIPTION DESCRIPCION	5XB4	5XR3	REMARKS OBSERVACIONES
1	4VP-H4700-00	TAILLIGHT ASSY FARO TRASERO COMPLET.	1	1	
2	4TE-H4714-00	.BULB .BOMBILLA	1	1	
3	4VP-H3342-00	.LENS, FLASHER 2 .LENTE DE DESTELLADOR	1	1	
4	4VP-H3332-00	.LENS, FLASHER .LENTE DE DESTELLADOR	1	1	
5	4VP-H4721-00	.LENS, TAILLIGHT .LENTE DE FARO TRASERO	1	1	
6	4VP-H4743-00	.LENS, LICENCE LIGHT .LENTE DE LUZ DE LICENCIA	1	1	
7	4VP-H3331-00	.BULB, FLASHER .AMPOLLETA DE DESTELLADOR	2	2	
8	97707-40616	.SCREW, TAPPING .TORNILLO ROSCA HEMBRA	2	2	
9	90119-06079	BOLT, WITH WASHER TORNILLO CON ARANDELA	2	2	
10	90183-05807	NUT, SPRING TUERCA DE RESORTE	4	4	
11	3KW-H5130-00	REAR REFLECTOR ASSY REFLECTOR TRASERO COMPLETO	1	1	
12	95707-05300	NUT, FLANGE TUERCA DE BRIDA	1	1	
13	4VP-H4519-00	BRACKET, TAILLIGHT SOPORTE DE FARO TRASERO	1	1	

FIG. 34 HANDLE SWITCH & LEVER

INTERRUPTOR DE MANILLAR&PALANC

REF. NO.	PART NO. CODIGO Nº	DESCRIPTION DESCRIPCION	5XB4	5XR3	REMARKS OBSERVACIONES
1	4VP-H2910-00	LEVER HOLDER ASSY (LEFT) SOPORTE DE LEVA COMPLT 1	1	1	
2	4VP-H3912-00	.LEVER 1 .PALANCA 1	1	1	
3	3XG-H3915-00	.SCREW, LEVER FITTING .TORNILLO ACCESORIO DE PALANC	1	1	
4	95607-05100	.NUT, U .TUERCA AUTOBLOCANTE	1	1	
5	98507-05020	.SCREW, PAN HEAD .TORNILLO DE CABEZA PLANA	1	1	
6	98507-05030	.SCREW, PAN HEAD .TORNILLO DE CABEZA PLANA	1	1	
7	3XG-H3980-10	.FRONT STOP SWITCH ASSY .INTERRUP. DE PARADA DELANTERO	1	1	
8	3XG-H3975-30	SWITCH, HANDLE 2 INTERRUPTOR DE MANIJA 2	1	1	
9	98506-05025	.SCREW, PAN HEAD .TORNILLO, DE CABEZA CRUZADA	1	1	
10	98506-05035	.SCREW, PAN HEAD .TORNILLO, DE CABEZA CRUZADA	1	1	
11	3GF-H3980-00	FRONT STOP SWITCH ASSY INTERRUP. DE PARADA DELANTERO	1	1	
12	4VP-H3922-10	LEVER 2 PALANCA 2	1	1	
13	90109-06577	BOLT PERNO	1	1	
14	95607-06100	NUT, U TUERCA AUTOBLOCANTE	1	1	
15	90501-10312	SPRING, COMPRESSION RESORTE DE COMPRESION	1	1	

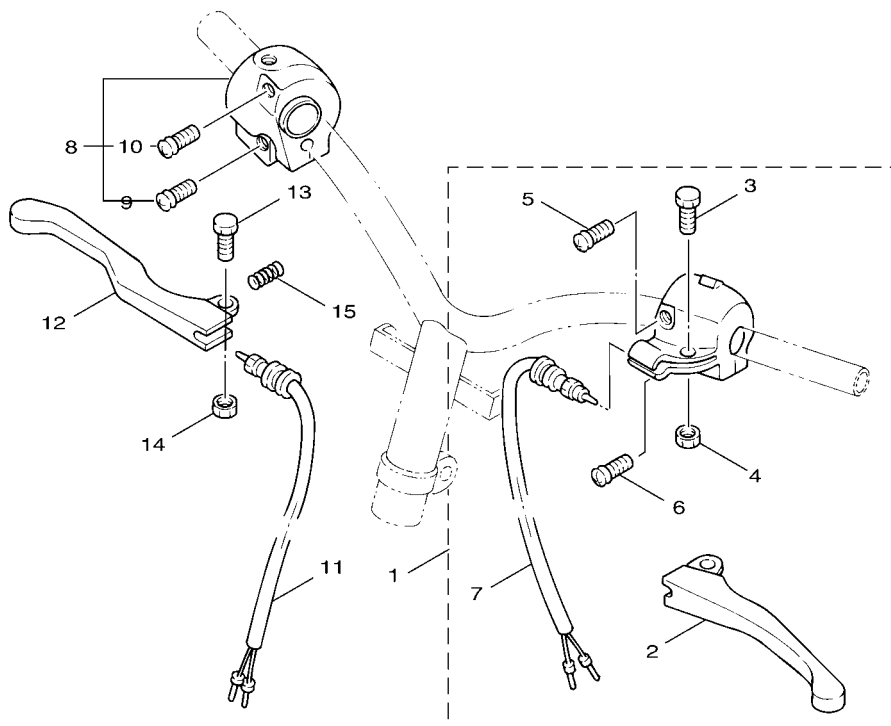

4VP1414-7420

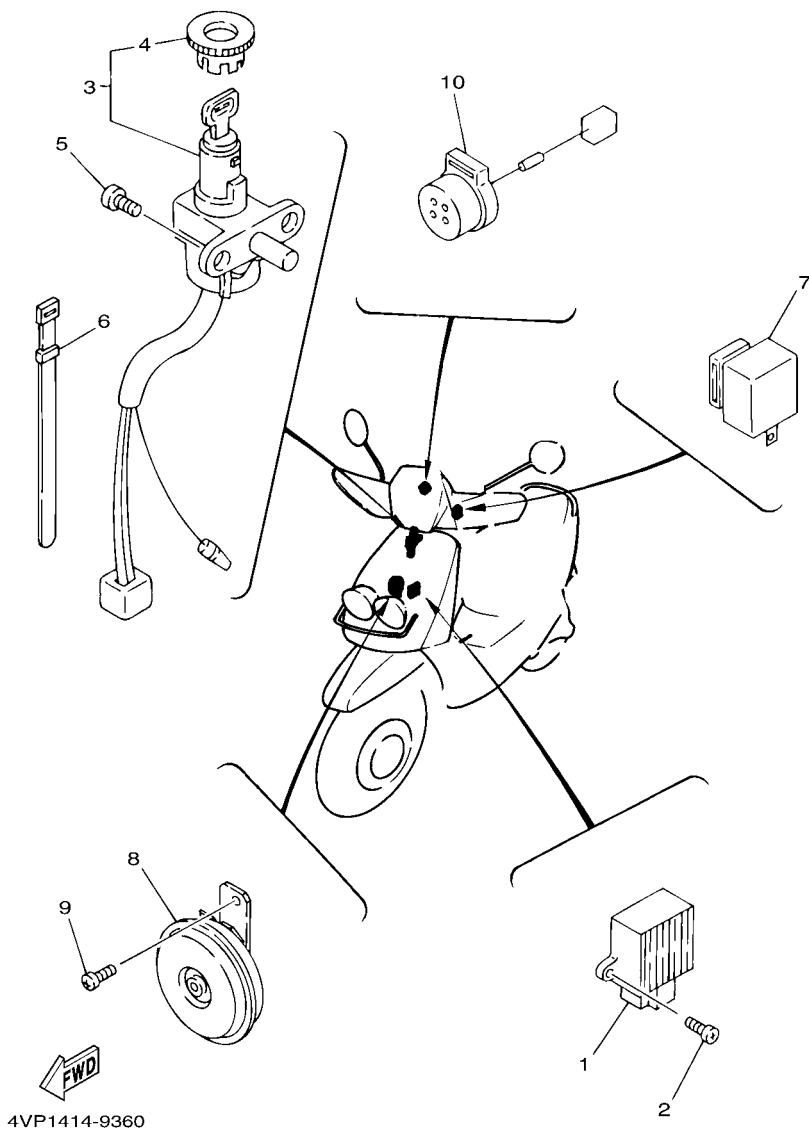

4VP1414-9360

FIG. 35 ELECTRICAL 1

EQUIPO ELECTRICO 1

REF. NO.	PART NO. CODIGO Nº	DESCRIPTION DESCRIPCION	5XB4	5XR3		REMARKS OBSERVACIONES
1	3GF-H1960-00	RECTIFIER & REGULATOR ASSY RECTIFICADOR Y REGULADOR	1	1		
2	98507-05010	SCREW, PAN HEAD TORNILLO DE CABEZA CON PLANA	2	2		
3	4VP-H2501-03	MAIN SWITCH STEERING LOCK LLAVE DE IGNICION COMPLT	1	1		
4	4VP-H2552-00	.CAP, SWITCH .TAPA DE INTERRUPTOR	1	1		
5	9760L-06216	SCREW, PAN HEAD WITH WASHER TORNILLO CAB CON PLANA C/ARAN	2	2		
6	23Y-H3936-00	BAND, SWITCH CORD BANDA DE CABLE DE INTERRUPTOR	2	2		
7	1MH-H3350-V0	FLASHER RELAY ASSY RELE DE DESTELLADOR COMPL.	1	1		
8	4KP-H3371-01	HORN BOCINA	1	1		
9	98507-06010	SCREW, PAN HEAD TORNILLO DE CABEZA PLANA	1	1		
10	3XY-H3390-01	AUDIO PILOT ASSY ALAR	1	1		

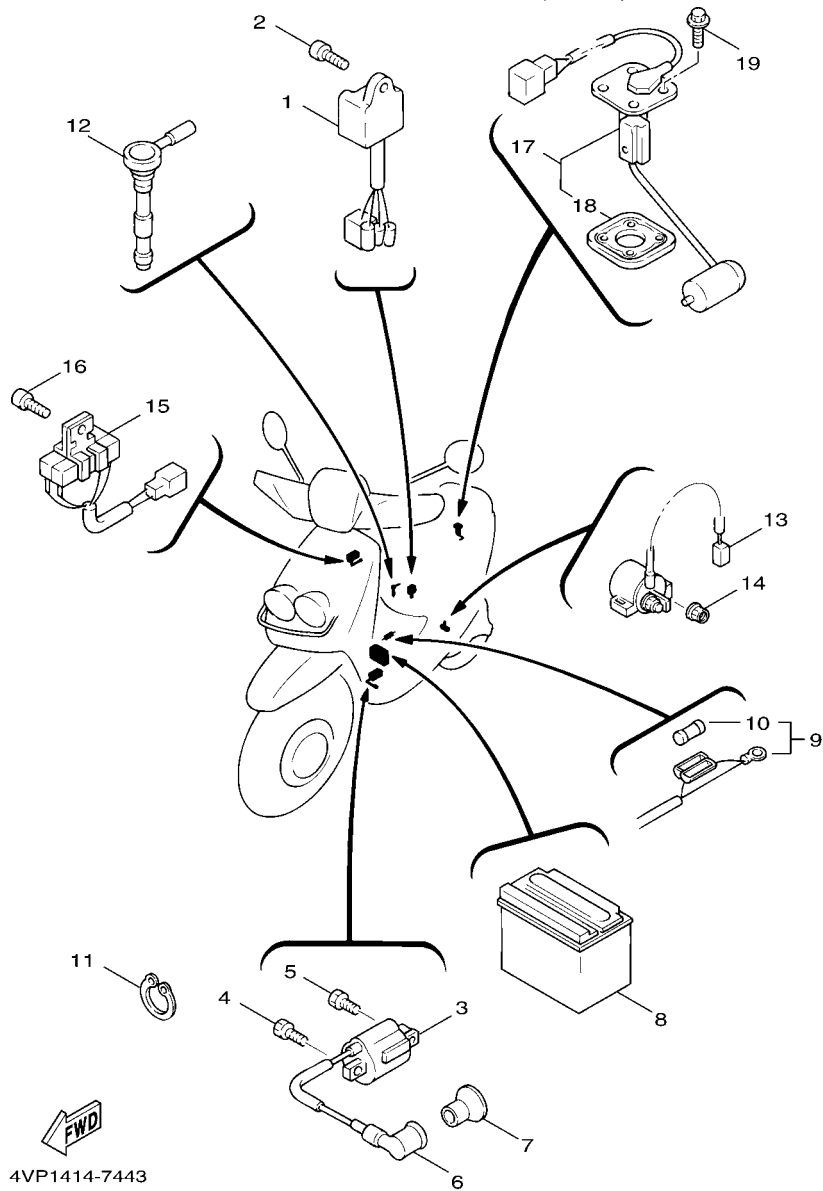

FIG. 36 ELECTRICAL 2

EQUIPO ELECTRICO 2

REF. NO.	PART NO. CODIGO Nº	DESCRIPTION DESCRIPCION	5XB4	5XR3	REMARKS OBSERVACIONES
1	4DM-H5540-00	C.D.I. UNIT ASSY UNIDAD C.D.I. COMPLETA	1	1	
2	90159-06056	SCREW, WITH WASHER TORNILLO CON VALONA	1	1	
3	4VP-H2310-01	IGNITION COIL ASSY BOBINA DE ENCENDIDO COMPLETA	1	1	
4	97007-06016	BOLT PERNO	1	1	
5	90153-06839	SCREW, HEXAGON TORNILLO HEXAGONAL	1	1	
6	4VP-H2370-00	PLUG CAP ASSY TAPON DE BUJIA COMPLT	1	1	
7	4VP-H2372-00	SEAL, PLUG CAP SELLO DE TAPON	1	1	
8	5HK-H2100-10	BATTERY ASSY BATERIA COMPLETA	1	1	
9	4VP-H2590-10	WIRE HARNESS ASSY CONJUNTO DE CABLES	1	1	
10	1NT-H2151-00	.FUSE .FUSIBLE	1	1	
11	90465-13275	CLAMP BRIDA	2	2	
12	4VP-H5720-00	OIL LEVEL GAUGE ASSY MEDIDOR DE NIVEL DE ACEITE	1	1	
13	3KW-H1940-02	STARTER RELAY ASSY CONJUNTO ARRANCADOR RELEVO	1	1	
14	95307-06600	NUT TUERCA	2	2	
15	3GF-H5370-01	RESISTOR ASSY RESISTOR COMPLETO	1	1	
16	98507-06020	SCREW, PAN HEAD TORNILLO DE CABEZA CON PLANA	1	1	
17	4VP-X8575-00	SENDER UNIT ASSY MEDIDOR DE COMBUSTIBLE COMPL.	1	1	
18	53X-H5753-00	.GASKET, SENDER UNIT .EMPAQUE DE UNIDAD TRANSMISORA	1	1	
19	90119-05071	BOLT, WITH WASHER TORNILLO CON ARANDELA	4	4	

NUMERICAL INDEX
INDICE NUMERICO

PART NO. CODIGO Nº	REF. NO.	PART NO. CODIGO Nº	REF. NO.	PART NO. CODIGO Nº	REF. NO.	PART NO. CODIGO Nº	REF. NO.	PART NO. CODIGO Nº	REF. NO.	PART NO. CODIGO Nº	REF. NO.
3AA-13124-00	4 - 5	4VP-E2658-00	3 - 10	4VP-E5512-00	9 - 7	4VP-F171E-00-P8	14 - 16	1MH-F3411-00	17 - 30	4VP-F6141-00	27 - 9
4VP-13178-00	4 - 15	4VP-E2659-00	3 - 11	4VP-E5524-00	9 - 1	4VP-F171E-00-PA	14 - 16	4TE-F3416-00	17 - 49	4VP-F6142-00	27 - 15
3WF-13185-00	4 - 2	5FA-E3100-11	4 - 1	3XG-E5532-00	9 - 11	4VP-F1733-00	15 - 3	4VP-F3418-00	17 - 48	4VP-F6143-00-P0	27 - 1
1YU-13187-00	4 - 3	4VP-E316F-00	4 - 8	4CW-E5570-00	9 - 5	4VP-F1734-00	15 - 4	3KW-F3462-00	17 - 31	4VP-F6143-00-P3	27 - 1
1YU-13473-00	4 - 4	3XG-E3342-00	9 - 9	4VP-E5601-00	9 - 13	4VP-F1741-00	14 - 13	4VP-F4110-10-33	18 - 1	4VP-F6143-00-P8	27 - 1
1YU-13516-00	4 - 6	4WX-E3555-10	5 - 6	5FA-E5620-00	9 - 18	4VP-F1745-00	15 - 7	4VP-F414A-10	18 - 10	4VP-F6143-00-PA	27 - 1
1YU-13577-00	4 - 7	3XG-E3575-01	5 - 8	4VP-E5630-00	9 - 20	4VP-F1751-00	15 - 1	4VP-F4311-00	18 - 7	4VP-F6145-00	27 - 2
4UF-14103-00	6 - 18	4VP-E3610-00	5 - 1	4VP-E5650-00	9 - 6	4TE-F1753-00	18 - 11	4CW-F4500-10	18 - 3	3GF-F6199-00	26 - 13
3MB-14104-00	6 - 12	3XG-E3613-00	5 - 2	4VP-E5659-00	8 - 19	4X6-F1771-02	15 - 6	4CW-F452K-10	18 - 4		27 - 5
3XG-14107-00	6 - 19	3XG-E3616-00	5 - 3	4VP-E5673-00	9 - 21	5XB-F1781-00	14 - 6	4VP-F4610-01	18 - 9	4VP-F6225-00	27 - 20
4VP-14112-35	6 - 5	4SC-E3621-00	5 - 5	4VP-E6111-01	10 - 1	5XB-F1782-00	14 - 10	4VP-F4726-00	19 - 5	4VP-F6240-00	23 - 5
52W-14131-00	6 - 3	5JU-E4101-00	6 - 1	4VP-E6611-00	10 - 15	5XB-F1783-00	14 - 6	4CW-F4726-01	19 - 3	4VP-F6241-00	23 - 4
4VP-14141-11	6 - 7	4VP-E4411-00	5 - 11	3XY-E6620-01	10 - 5	5XB-F1783-10	14 - 6	5PJ-F4730-00	19 - 1	4VP-F6260-02	23 - 8
193-14142-35	6 - 11	4VP-E4412-00	5 - 14	3UH-E6626-00	10 - 6	5XB-F1784-00	14 - 10	4VP-F4738-10	19 - 13	4VP-F6262-00	23 - 11
52W-14147-00	6 - 17	4VP-E4437-00	5 - 12	4VP-E7211-01	11 - 7	5XB-F1784-10	14 - 10	4VP-F473R-01	19 - 8	4VP-F6266-00	23 - 13
18A-1414A-65	6 - 9	4VP-E443E-00	5 - 22	4VP-E7410-01	11 - 1	4VP-F1851-00	26 - 22	4VP-F4742-00	19 - 10	4VP-F6280-00	27 - 7
522-14161-00	6 - 22	4VP-E4445-00	7 - 2	4VP-E7421-01	11 - 6	5JU-F2210-00	16 - 1	4VP-F475M-00	19 - 2	4VP-F6290-00	27 - 6
4VP-14171-00	6 - 16	4VP-E4451-00	5 - 19	4VP-E7611-00	10 - 25	4X6-F2216-00	8 - 3	4UE-F4780-02	19 - 15	4VP-F6311-01	23 - 7
53L-14186-00	6 - 20	4VP-E4452-00	5 - 20	4VP-E7620-00	10 - 17	4WX-F3100-14-33	17 - 1	4VP-F478E-00	19 - 17	4VP-F6312-01	23 - 10
4KP-14191-00	6 - 13	4VP-E4453-00	5 - 15	4VP-E7623-00	10 - 20	4WX-F3102-10-33	17 - 2	4VP-F4812-01-1V	19 - 19	4VP-F6321-02	23 - 9
3XG-14196-00	6 - 10	4VP-E4462-00	5 - 17	4CW-E7653-00	10 - 21	4WX-F3103-10-33	17 - 15	20A-F5115-00	20 - 3	1MH-F6329-00	6 - 23
3XG-14198-00	6 - 2	4VP-E4463-00	5 - 16	4VP-E7660-01	10 - 7	4WX-F3110-00	17 - 4	4WX-F5180-01-33	20 - 1	4VP-F6351-01	23 - 15
4VP-1490J-00	6 - 6	4VP-E4467-00	5 - 18	4DM-E7664-00	10 - 11		17 - 17	4WX-F5181-00	20 - 9	4VP-F637G-00	23 - 17
3XG-14997-00	6 - 8	5JU-E4610-00-98	7 - 1	4VP-E7670-01	10 - 8	4JL-F3126-00-33	17 - 3	4WX-F5183-00	20 - 2	4VP-F6393-00	23 - 16
14T-15657-00	10 - 27	3NT-E4613-01	7 - 4	4DM-E7684-00	10 - 13	4JL-F3136-00-33	17 - 16	4VP-F5190-10	20 - 11	4VP-F7111-01	25 - 1
4KX-17632-00	10 - 19	4VP-E4627-10	7 - 9	5XB-F1110-00-33	12 - 1	4WX-F3141-10	17 - 6	1P3-F5326-00	22 - 5	4CW-F7114-00	25 - 2
4VP-17641-00	10 - 24	4VP-E4718-00	7 - 8	5XR-F1110-00-33	12 - 1		17 - 19	4WX-F5336-00	22 - 2	4VP-F7311-01	25 - 12
22F-23411-01	17 - 43	4VP-E475M-00	7 - 14	3KW-F139X-00	19 - 12	5SU-F3145-00	17 - 13	4VP-F533A-00	22 - 12	5PJ-F7411-00	25 - 16
156-23412-00	17 - 50	3XY-E4766-00	7 - 19	4Y4-F139X-01	12 - 7		17 - 26	3UH-F5351-00	22 - 10	5PJ-F7421-00	25 - 17
22F-23412-01	17 - 44	4CW-E4766-00	7 - 11	4VP-F1410-30	12 - 6	3GF-F3147-00	17 - 10	4WX-F5355-00	22 - 11	45U-F8100-00	12 - 11
4VP-E1111-00	1 - 1		7 - 17	3XG-F1481-00	12 - 2		17 - 23	4WX-F5390-00-33	22 - 1	23Y-F8175-00	12 - 12
4VP-E1162-00	1 - 4	4VP-E4779-00	7 - 3	4Y4-F1481-00	12 - 4	4WX-F3154-00	17 - 9	5JU-F580T-00	21 - 4	4VP-F8257-01	26 - 18
4VP-E1181-00	1 - 2	4VP-E4799-20	7 - 13	4VP-F1511-01	13 - 1		17 - 22	3XG-F582T-00	21 - 1	4VP-F8300-01	26 - 7
4VP-E1311-10-A0	1 - 5	5FA-E5111-12	8 - 1	4VP-F1514-00	12 - 9	3NW-F3156-00	17 - 14	3GF-F5852-00	24 - 4	5XB-F832B-00	26 - 2
5FA-E1351-00	1 - 6	4VP-E5118-00	8 - 31	4VP-F1519-01	13 - 6		17 - 27	3GF-F5854-00	24 - 3	5XB-F832C-00	26 - 3
4VP-E1400-00	2 - 1	4VP-E5121-00	8 - 2	5XB-F152A-00	26 - 4	3GF-F3158-00	17 - 7	3GF-F5867-00	24 - 6	5XB-F832K-00	26 - 2
4VP-E1412-00	2 - 2	4VP-E5128-00	8 - 28	5XB-F152A-20	26 - 4		17 - 20	4JL-F5870-02	24 - 1	5XB-F832K-10	26 - 2
4VP-E1422-00	2 - 6	3XG-E5317-00	8 - 9	5XB-F152A-30	26 - 4	4WX-F3170-00	17 - 5	4VP-F5872-13	24 - 8	5XB-F832L-00	26 - 3
4VP-E1603-00	2 - 15	4Y4-E5363-00	8 - 24	4TH-F152A-E0	26 - 4		17 - 18	4VP-F5875-01	17 - 33	5XB-F832L-10	26 - 3
4VP-E1631-10-A0	2 - 13	3XG-E5371-00	8 - 5	2GF-F1535-00	14 - 4	3GF-F3181-00	17 - 8	4VP-F5876-00	17 - 35	5FM-F8349-00	26 - 8
4VP-E1633-00	2 - 14	4VP-E5373-00	8 - 6	4VP-F1535-00	26 - 16		17 - 21	5FA-F5876-00	17 - 34	4VP-F834V-00	26 - 5
4VP-E1651-00	2 - 5	4VP-E5411-00-33	8 - 17	4VP-F1552-00	13 - 4	4WX-F3191-10	17 - 11	5FJ-F5886-00	17 - 40	4VP-F8385-11	26 - 11
4DM-E1681-00	2 - 3	4VP-E5421-01	8 - 11	4JK-F1568-00	26 - 9		17 - 24	3XG-F5919-01	21 - 8	4VP-F838K-00	26 - 20
4VP-E2611-00	3 - 12	4VP-E5439-00	8 - 16	4VP-F1629-00	13 - 9	4TE-F3192-00	17 - 12	3XG-F5919-11	21 - 9	4VP-F840K-00-1V	26 - 14
4DY-E262H-00	3 - 4	5DA-E5451-00	8 - 18	4VP-F1691-01	13 - 12		17 - 25	3XG-F5926-01	21 - 10	3GF-H1403-V0	28 - 2
3XG-E2631-00	3 - 15	5DA-E5461-00	8 - 12	4VP-F1711-00	14 - 1	3GF-F3317-00	17 - 32	4VP-F6110-20	23 - 1	4VP-H1800-20	29 - 1
5FA-E2651-10	3 - 1	4SC-E5462-00	8 - 30	4VP-F171E-00-P0	14 - 16	5PJ-F3340-01	17 - 29	4VP-F612M-01	27 - 10	4DM-H1801-00	29 - 2
5FA-E2653-02	3 - 3	4VP-E5477-00	8 - 33	4VP-F171E-00-P3	14 - 16	3GF-F3346-00	17 - 28	4VP-F612N-01	27 - 16	3NW-H1828-V0	29 - 5

NUMERICAL INDEX
INDICE NUMERICO

PART NO. CODIGO Nº	REF. NO.	PART NO. CODIGO Nº	REF. NO.	PART NO. CODIGO Nº	REF. NO.	PART NO. CODIGO Nº	REF. NO.	PART NO. CODIGO Nº	REF. NO.	PART NO. CODIGO Nº	REF. NO.
3KW-H1940-02	36 - 13	4VP-H4332-00	32 - 6	90116-07834	1 - 7	90201-155G5	9 - 16	90480-16278	14 - 14	93306-200Y1	11 - 3
3GF-H1960-00	35 - 1	4VP-H4337-00	32 - 9	90119-05062	17 - 39	90201-15819	11 - 4	90501-08845	4 - 12	93306-203YE	10 - 2
5HK-H2100-10	36 - 8	4VP-H4351-00	32 - 11	90119-05071	36 - 19	90201-163G6	9 - 4	90501-10312	34 - 15		11 - 12
1NT-H2151-00	36 - 10	4VP-H4359-00	32 - 4	90119-06079	25 - 18	90201-16800	10 - 23	90501-165J7	23 - 20	93306-205Y6	2 - 9
4VP-H2310-01	36 - 3	4VP-H4519-00	33 - 13		33 - 9	90201-203E7	22 - 16	90501-29517	12 - 8	93306-300Y4	20 - 5
4VP-H2370-00	36 - 6	4VP-H4700-00	33 - 1	90119-06802	15 - 2	90202-05193	18 - 6	90501-430K3	10 - 12	93310-21403	2 - 17
4VP-H2372-00	36 - 7	4TE-H4714-00	33 - 2	90119-06821	13 - 2	90202-10120	25 - 5	90506-16447	22 - 9	93310-41810	2 - 4
4VP-H2501-03	35 - 3	4VP-H4721-00	33 - 5		25 - 9	90202-26142	17 - 47	90506-26805	25 - 15	93311-315Y2	11 - 2
4VP-H2552-00	35 - 4	4VP-H4743-00	33 - 6	90119-06857	3 - 14	90202-26166	29 - 6	90506-32857	25 - 7	93315-108Y4	9 - 8
4VP-H2590-10	36 - 9	3KW-H5130-00	33 - 11	90149-05821	27 - 12	90208-12050	10 - 28	90508-32768	9 - 14	93410-20823	11 - 8
4VP-H2910-00	34 - 1	3GF-H5370-01	36 - 15		27 - 18	90208-21801	11 - 5	91317-06016	19 - 21	93450-16115	2 - 16
4VP-H3310-00	30 - 1	4DM-H5540-00	36 - 1	90149-06011	18 - 5	90209-14800	10 - 26	91317-06025	8 - 21	93450-35015	9 - 3
4VP-H3311-00	30 - 3	4KX-H5550-00	28 - 9	90153-06800	7 - 5	90209-18112	2 - 7		24 - 7	93501-04011	17 - 51
		3XG-H5560-00	28 - 1	90153-06839	36 - 5	90240-10137	25 - 3	91317-06035	8 - 22	93503-16003	17 - 45
4VP-H3312-00	30 - 2	3GF-H5580-V0	28 - 3	90159-05820	27 - 11	90241-10015	19 - 7	91317-06045	8 - 23	93603-12827	4 - 16
4VP-H3313-00	30 - 5	4VP-H5720-00	36 - 12		27 - 17	90249-12008	23 - 19		19 - 20	93900-00802	20 - 7
		53X-H5753-00	36 - 18	90159-05831	27 - 3	90280-03017	2 - 8	91318-06020	5 - 7		22 - 4
4VP-H3320-00	30 - 6	3GF-W0041-00	24 - 2	90159-06056	36 - 2	90338-16148	26 - 17		8 - 15	94112-108S3	20 - 6
4VP-H3322-00	30 - 7	5JU-W0045-00	21 - 11	90159-06811	26 - 19	90380-15817	9 - 15		29 - 7	94113-108S4	22 - 3
4VP-H3331-00	33 - 7	3XG-W0047-00	21 - 6	90159-06812	26 - 6	90387-068F8	13 - 3	91318-06035	8 - 8	94700-00825	1 - 3
4VP-H3332-00	33 - 4	3XG-W0048-00	21 - 7	90159-06822	14 - 3	90387-068J5	3 - 6		8 - 14	95027-06010	11 - 14
4VP-H3342-00	33 - 3	3XG-W0057-00	21 - 5	90160-05803	27 - 4		5 - 25	91810-14807	8 - 13	95027-06020	26 - 15
1MH-H3350-V0	35 - 7	4VP-W1441-00	5 - 10	90163-05800	32 - 16	90387-104U5	20 - 10		8 - 20	95307-06600	36 - 14
4KP-H3371-01	35 - 8	4VP-W1442-00	5 - 13	90167-03800	23 - 12	90387-168N7	10 - 22	91812-16805	8 - 7	95307-12600	28 - 11
3XY-H3390-01	35 - 10	4VP-W2620-03	23 - 6	90176-06065	7 - 16	90387-178N6	2 - 12	91A10-07056	18 - 12	95307-12700	10 - 29
4VP-H3509-00	31 - 3	4VP-X2172-20-P8	14 - 5	90179-06411	23 - 18	90401-10805	24 - 9	92901-04100	28 - 8	95607-05100	34 - 4
4VP-H3510-00	31 - 1	4VP-X2172-20-PA	14 - 5	90179-07381	1 - 8		24 - 10	92907-06200	7 - 15	95607-06100	17 - 38
3GF-H3517-00	31 - 4	4VP-X2172-80-P3	14 - 5	90179-10609	10 - 16	90430-08119	8 - 27	92907-06600	19 - 22		34 - 14
4VP-H3517-00	31 - 5	4VP-X2172-C0-P0	14 - 5	90179-25615	17 - 46	90445-05431	4 - 10	92907-12600	28 - 10	95607-12200	12 - 3
4TE-H3518-00	31 - 6	4VP-X2173-20-P8	14 - 9	90179-28415	10 - 14	90445-078A3	18 - 14	93101-20169	2 - 11	95707-05300	33 - 12
4VP-H353K-00	31 - 2	4VP-X2173-20-PA	14 - 9	90183-05807	13 - 8	90445-105H0	18 - 15	93101-21801	10 - 18	95707-06500	18 - 2
4VP-H3550-03	31 - 8	4VP-X2173-80-P3	14 - 9		13 - 15	90460-27815	15 - 8	93102-17467	10 - 3		19 - 4
4VP-H3912-00	34 - 2	4VP-X2173-C0-P0	14 - 9		14 - 7	90460-35260	26 - 23	93102-17838	20 - 4		19 - 6
3XG-H3915-00	34 - 3	4WX-X2533-00	22 - 8		14 - 12	90460-41191	5 - 27	93102-22464	2 - 10		19 - 14
4VP-H3922-10	34 - 12	4VP-X2831-10-P7	26 - 1		19 - 9	90464-16801	4 - 11	93102-25270	11 - 10	95707-10500	16 - 4
23Y-H3936-00	35 - 6	4VP-X2831-10-P8	26 - 1		25 - 10	90465-13275	27 - 8	93104-19097	28 - 4		22 - 6
3XG-H3975-30	34 - 8	4VP-X2831-80-P3	26 - 1		33 - 10		36 - 11	93104-33800	10 - 9	9570L-10500	21 - 3
3GF-H3980-00	34 - 11	4VP-X2831-B0-P0	26 - 1	90185-10037	25 - 14	90467-01800	5 - 9	93210-07890	22 - 7	95807-06010	17 - 42
3XG-H3980-10	34 - 7	4VP-X8575-00	36 - 17	90185-10801	12 - 5	90467-08003	4 - 9	93210-108B1	25 - 4	95807-06012	13 - 5
4VP-H4144-00	32 - 13	5PJ-XF748-00	25 - 8		20 - 8	90467-09006	18 - 8	93210-14805	8 - 25		13 - 10
4VP-H4169-00	32 - 15	90101-06878	22 - 13		23 - 3		18 - 13	93210-23614	29 - 4		27 - 13
4VP-H4198-00	32 - 8	90102-10031	16 - 3	90185-14124	22 - 15	90467-11823	5 - 23	93210-368G9	10 - 10		27 - 19
4VP-H430A-00	32 - 1	90105-08121	16 - 2	90201-06380	13 - 11	90468-02033	4 - 13	93210-44678	29 - 3	95807-06014	26 - 21
3UH-H4314-10	32 - 10	90105-10036	23 - 2	90201-064J1	17 - 37	90468-12006	16 - 5	93210-64893	3 - 13	95807-06016	32 - 12
4VP-H4317-00	32 - 2	90109-063F1	19 - 11	90201-06847	11 - 13		25 - 6	93306-003Y4	8 - 4	95807-08014	27 - 14
4VP-H4318-00	32 - 3	90109-06577	34 - 13	90201-08088	9 - 10	90480-11866	3 - 2		9 - 2	95807-08016	8 - 26
4VP-H431V-00	32 - 7	90109-10473	25 - 13	90201-10118	24 - 11	90480-12497	3 - 7	93306-004X7	11 - 9	95807-08035	12 - 10
4VP-H4331-00	32 - 5	90110-10811	21 - 2	90201-142M6	22 - 14		5 - 26	93306-200Y1	10 - 4	9580L-06012	17 - 41

NUMERICAL INDEX
INDICE NUMERICO

PART NO. CODIGO N°	REF. NO.	PART NO. CODIGO N°	REF. NO.	PART NO. CODIGO N°	REF. NO.	PART NO. CODIGO N°	REF. NO.	PART NO. CODIGO N°	REF. NO.	PART NO. CODIGO N°	REF. NO.
95817-06020	17 - 36	98507-05020	34 - 5								
95817-08020	7 - 6	98507-05030	34 - 6								
95817-08030	7 - 7	98507-06010	35 - 9								
95827-08030	21 - 12	98507-06012	8 - 29								
97007-06016	19 - 16		8 - 32								
	36 - 4		9 - 12								
97017-06010	7 - 10	98507-06016	28 - 12								
97017-06025	9 - 19	98507-06020	36 - 16								
97507-05510	15 - 5	98706-04012	24 - 5								
97517-06510	7 - 12	98980-06010	7 - 18								
97607-03206	5 - 4	99009-15400	9 - 17								
97607-04108	6 - 14	99009-17400	8 - 10								
97607-04112	6 - 4	99009-19400	4 - 17								
97607-06220	3 - 8	99009-42500	11 - 11								
	5 - 24										
	8 - 34										
9760L-06216	35 - 5										
97707-40514	3 - 5										
97707-40610	30 - 4										
	30 - 9										
97707-40616	33 - 8										
97707-50012	13 - 13										
	14 - 2										
	14 - 8										
	14 - 11										
	14 - 15										
	14 - 17										
	32 - 14										
97707-50016	13 - 7										
	13 - 14										
	25 - 11										
	26 - 10										
	26 - 12										
	31 - 7										
97707-50125	5 - 21										
97707-60540	3 - 9										
98501-04008	28 - 7										
98501-05010	28 - 6										
98501-05020	28 - 5										
98506-05025	34 - 9										
98506-05035	34 - 10										
98507-03006	6 - 15										
98507-04012	6 - 21										
98507-05010	19 - 18										
	23 - 14										
	30 - 11										
	35 - 2										
98507-05014	4 - 14										